

INSTRUCTION MANUAL

WESTAMP A651 SERIES REV. F

This is a general manual describing a whole series of amplifiers and may be used in conjunction with drawings pertaining to various specific models.

CAUTION

The maintenance procedure described herein should be attempted only by highly skilled technicians using proper test equipment. Read your warranty provisions before starting, to avoid voiding your warranty.

Westamp Inc.

9006 Fullbright Avenue
Chatsworth, California 91311

PHONE: (818) 709-5000 FAX: (818) 709-8395

TABLE OF CONTENTS

DESCRIPTION	PAGE
FOREWORD	1
SPECIFICATIONS	2 & 3
BLOCK DIAGRAM	4
DESCRIPTION OF BLOCK DIAGRAM	5
PROTECTIVE FEATURES	6 & 7
POWER SUPPLY REGULATOR	7
INSTALLATION INSTRUCTIONS	8
INSTALLATION DRAWING	9
ADJUSTMENTS	10
BOARD LAYOUT (SIMPLIFIED)	11
SYSTEM COMPENSATION	12, 13 & 14
HELPFUL COMPENSATION HINTS	15
TROUBLE SHOOTING AIDS	16
TROUBLE SHOOTING TABLE	17
TROUBLE SHOOTING MULTI-AXES	18
BOARD LAYOUT (DETAILED)	18
DIFFERENTIAL BOARD (OPTION)	19
SCHEMATIC	20 & 21
APPLICATION NOTE: POTENTIOMETERS	22
APPLICATION NOTE: SERIES INDUCTORS	23
AMPLIFIER FINAL SETTINGS	24

FOREWORD

This is a general purpose manual, covering the theory and application of the A6511 Series of Pulse Width Modulated Servo Amplifiers.

Each A6511 Pulse Width Modulated Amplifier consists of chassis which contains the following:

- A) The Module with the control circuits, and output transistors.
- B) The bias power supply which provides plus and minus 15 volts, the main output power supply, the terminal block with the input and output connections for the power section, protective fuses and a UL listed blower.

SPECIFICATIONS:	A651X-10C	10E	10F
1. Peak Current	±15 A	±22 A	±30 A
2. Peak Voltage (typ)	±100 VDC	±100 VDC	±100 VDC
3. Continuous Current	±10 A	±10 A	±15 A
4. Continuous Voltage (typ)	±92 VDC	±92 VDC	±92 VDC
5. Horsepower Rating (cont)	1.25 HP	1.25 HP	1.85 HP
6. Form Factor	1.001	1.005	1.005
7. Switching Freq. (constant)	16 KHz	5 KHz	5 KHz
8. Input Voltage	10 VAC to 70 VAC Bus Power, 120 VAC at 2 amps Bias power		
9. Freq. Response	500 Hz min.		
10. Dead Band	None		
11. Gain (multiturn) pots			
Input 1 (Aux)	0 to 6000 A/V		
Input 2 (Signal)	0 to 6000 A/V		
Input 3 (Tach)	0 to 6000 A/V		
12. Signal Input Impedance	20K min.		
13. Signal Input Voltage			
Typical	±10 Volts		
Max	±50 Volts		
14. Drift (Refer to Input)	10 microvolts/°C		
15. Current Limit (multiturn) pots	Adjustable/Programmable		
16. Signal Balance	Adjustable		
17. Ambient Temp. (Operating)	0-50°C		
18. Auxiliary Inputs	Gain reduction Limit switch overtravel shut down Remote on off (electronic) Programmable current limit		
19. Auxiliary Outputs	Output current monitor		
20. System Compensation	Adjustable & built in		
21. PROTECTION			
a)	Shorts to ground either leg		
b)	Shorts across output		
c)	RMS overload (electronic)		
d)	Bias fault protection		
e)	Overvoltage indication		
f)	Overtemperature shut down		
g)	Current limit		
h)	Bias fuse		
22. Cooling	Blower		
23. Weight	5 lbs. (1 axis)		
24. Mounting	Panel (Vert/Horiz)		
25. Power transformer separate. May be supplied by customer			

MODEL	NO. OF AXES	CHASSIS SIZE** (INCHES)		
		L	W	H
A6511	1	10 ³ / ₈	5	7
A6512	2	10 ¹ / ₂	9 ¹ / ₄	7
A6513 or 4	3 or 4	10 ¹ / ₂	13	7

** Includes power supply & (regulator)

NOTES:

1. Peak current is for 500 millsec.
2. Freq. response is typical of the amplifier with no compensation. Servo compensation networks in practical applications usually reduce the response.
3. Consult the factory concerning applications requiring continuous regeneration.
4. 120 VAC is for blower power & bias power.
5. Output voltage max is from 70 VAC RMS bus power.
6. The amplifier provides a wide range of output voltages, depending on input voltage.
7. If the motor has 2 mhy (10F Model) or 2.6 mhy (10E Model) or 1.3 mhy (10C Model), no external inductor is necessary.
8. The output current monitor is capable of driving a zero center 50 microampere meter with suitable series resistance such as 71.5K. With a 50-0-50 microampere meter and a 71.5K series resistor the scale indication will be in amperes.
9. If red light is on, this indicates trip of fault logic. Remove power-wait 10 seconds-reapply power. The amplifier will restart if fault has cleared.

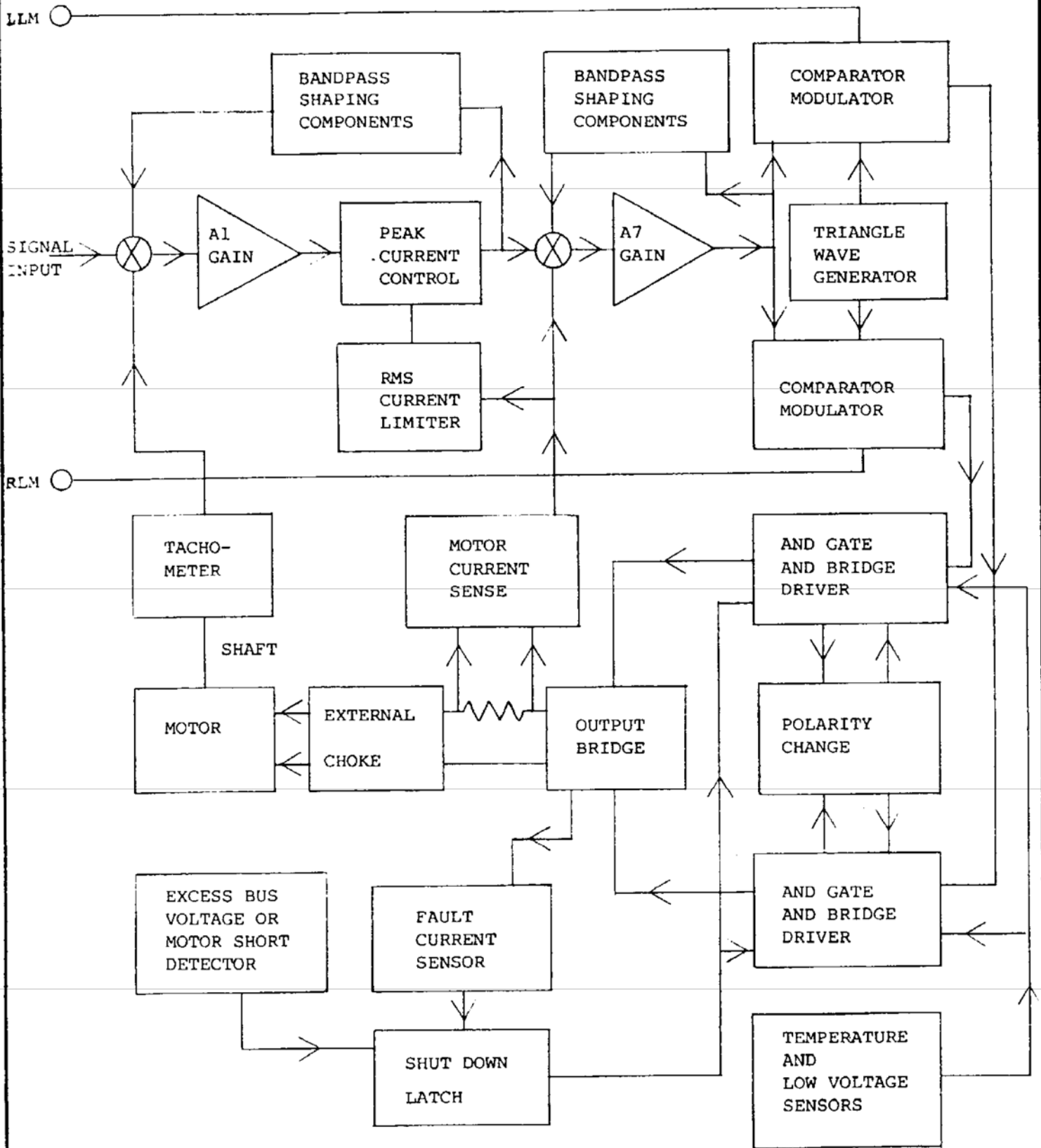

BLOCK DIAGRAM

FIG #1

Description of A651 Block Diagram

The A651 amplifier consists of a closed loop feedback amplifier which has a second closed loop within the outer loop. Referring to the Block Diagram, analysis may begin at the signal input point at the left side of the page. The signal input comes to a summing point designated as a circle with a cross in it. The signal input and the tachometer input are of opposite polarity and are normally almost equal in magnitude. The difference between the signal input and the tachometer input becomes an error signal which is amplified in the amplifier designated A1 gain.

At the output of A1 gain is a peak current control which limits the maximum output swing. This network has another function, that is, a shut-down capability by the RMS current limiter. The bandpass shaping components couple part of the peak current control output back to the first summing point. These components are usually necessary to accomplish a stable servo system.

The above output is a command to the inner loop. The feedback to the inner loop summing point is from a motor current sense circuit which is sensing output current to a motor. Again, there is an error signal which is the difference between the command and feedback signal. This error signal is amplified in the A7 amplifier. Shaping components are included around this amplifier to accomplish a stable loop.

The amplifier error signal from A7 goes to two comparator modulators having inputs from a triangle wave generator. If the A7 output goes positive, one comparator modulator puts out wider and wider pulses at the frequency of the triangle wave generator. If the A7 output goes negative, the other comparator modulator puts out wider and wider pulses. LLM and RLM input commands from external right or left limit switches are capable of inhibiting the modulators.

One comparator modulator causes the motor to run in one direction. The other comparator modulator causes the motor to run in the second direction. Each comparator modulator goes to an AND gate and bridge driver circuit which, in turn, drives the output bridge. A polarity change box senses the action of each bridge driver and prevents turn on of the opposite bridge driver.

The output bridge delivers rectangular voltage pulses to an external choke which, in turn, is connected to a motor. Because the choke has inductance, the current which flows to the motor increases while the voltage pulse is present and decreases while the voltage pulse is missing.

The motor current sense circuit senses motor current through a very low value resistor. The fault current sensor measures current to the bridge from the power supply through another low value resistor. If excessive current is sensed, the fault current sensor shuts down the AND gates to turn off the bridge. Excess bus voltage or motor shorts can also trip the shut-down latch to turn off the gates.

PROTECTIVE FEATURES:

The A651X was the first unit in the marketplace to provide these advanced safety features. These safety features help protect personnel, machinery and the amplifier from accidents.

A) The amplifier will shut off and remain off plus turn on the red fault light if:

- 1) The motor or motor leads short from either side of armature to ground with or without an external inductor.
- * 2) The output leads of the amplifier should be inadvertently shorted together before the inductor.
- 3) The bus power supply voltage exceeds a safe level such as may occur during regeneration of a motor.
- 4) The temperature of the heatsink becomes excessive.
- 5) The sum of the two bias supplies is less than approximately 28 volts.

B) The amplifier will shut off and not turn on the red fault light

If the RMS is excessive for too long of a time.

NOTE: The unit will shut down the current and automatically come back on to full current after a second or two.

C) The amplifier will not be damaged but may shut off during the following:

- 1) If the amplifier output leads become shorted after the external inductor.
- 2) Input bus voltage down to zero volts.

* If an external inductor is not used in series with the motor, the amplifier output transistors may become damaged - - See application note at end of this manual.

NOTE: Under all conditions where the unit shuts off with light indication, it is necessary to remove bias power, wait approximately 15 seconds, then re-apply power.

OTHER FEATURES

Connector J-1

Pin 1 - Signal Input (Auxiliary)
Pin 2 - Signal Input (Standard)
Pin 3 - Signal Input (Tach)
Pin 4 - Signal Common
Pin 5 - Decoupled Current Sense - The output current of the amplifier is decoupled thru a mod/demod circuit. See Note 8 on Page 3.

Pin 6 & 7 - Limit Switch Overtravel - These circuits are used to prevent drive in one direction by grounding of Pin 6 or 7. Pin 6 is for one direction. Pin 7 is for the other direction.

- Pin 8 - Electronic shut down and trip indication. The output is turned off if Pin 8 is grounded. If high impedance instrumentation is connected to Pin 8, an internal shut down can be sensed remotely because internal circuits will permit Pin 8 to fall to ground level if shut down occurs. External instrumentation should be a higher impedance than 100,000 ohms to ground.
- Pin 9 - Common for Pins 6, 7, and 8.
- Pin 10 - +15 VDC bias power
50 MA is available for external use.
- Pin 11 - Common-bias power.
- Pin 12 - -15 VDC bias power
50 MA is available for external use.

NOTES: Pins 10, 11, 12 - - - if more than 50 MA is taken from these pins the bias power may sag and the amplifier may turn off. Reference Paragraph A under Protective Features.

Connector J-2

Pin 1 and Pin 2 may be connected together to reduce gain around velocity control amplifier when jumper installed gain of amplifier becomes 0 to 6 A/V. Pin 1 and Pin 3 are used for an external programmable current limit by installing an appropriate resistor for the desired current.

Connector J-3

Pin 1 +15 VDC bias power
Pin 2 common bias power
Pin 3 -15 VDC bias power

Power Supply Regulator (Shunt Regulator) (Optional)

During the slowing down or stopping of a DC motor, the motor regenerates. This energy is put back into the system. The system absorbs this in the form of pumping up the supply voltage capacitor.

If the supply voltage exceeds the set trip level of the overvoltage sensor, the fault sensor trips the unit off and the red light comes on. In order to keep the voltage on the capacitor within a safe level, it may be necessary to install a regulator. The regulator is protected against excessive dissipation by means of a fuse.

INSTALLATION:

Each amplifier in the A6511 Series comes with an individual installation drawing where to make the various connections for power input, signal input, tachometer input, fan and bias power input and output to the motor. While this manual may show in a general way how to make connections to amplifiers, it is imperative that the specific instructions applicable to your amplifier are followed. Always be certain to apply the correct input power voltage and frequency. The input power transformer for all the amplifiers in the A6511 Series are separately mounted. It is possible to use one power transformer for several amplifier units if that transformer is sized properly. These transformers may have dual voltage primaries and, in such cases, make certain that the jumpers are on the correct transformer terminals for your input AC power source. On the amplifier the motor output is taken from separate terminals mounted on TB-301.

CAUTION: DO NOT USE GROUNDED TEST EQUIPMENT ON THE OUTPUT CIRCUITS AND DO NOT CONNECT EITHER OF THE OUTPUTS TO GROUND.

The signal input is usually applied directly to Pin 2 of the J-1 and the signal common is usually applied to Pin 4 of J-1. The tachometer signal is usually applied to Pin 3 of J-1 and the tachometer return is connected to Pin 4 of J-1. The auxiliary signal is applied to Pin 1 and the auxiliary signal return is applied to Pin 4 of J-1. Use shielded wires for signal and tachometer inputs to prevent stray pickup and noise being introduced into the amplifier. The amplifier may have a bandwidth anywhere from 1000 Hz (no compensation) to a much lower frequency, depending upon the setting of the TC (time constant) potentiometer and the components in the servo compensation network. Figure 2 shows a typical installation drawing that could be used to test an amplifier-motor combination.

In many cases, a reactor is connected in series between the output of the amplifier and the motor. This reactor is required if the inductance of the motor is below a recommended value -- See Note 7 on specification sheet. The amplifiers in this series require up to 2 amperes of 115 volts for the fan and bias power at Terminals 1 and 2 of TB-301. In addition, the output voltage from the secondary of the transformer may be anywhere from 10 volts RMS to 72 volts RMS in accordance with the maximum output voltage required. The output of the secondary of the power transformer is connected to Terminals 5 and 6 of TB-301. Please be sure that all the connections are proper before applying power to the unit.

REV	DESCRIPTION	BY	DATE
A	Change F302 to MDA 20 Amp & Change F801 to MDA 5 Amp	4/1/50	

NOTE: AMPLIFIER MAX HEIGHT IS 7 1/2"

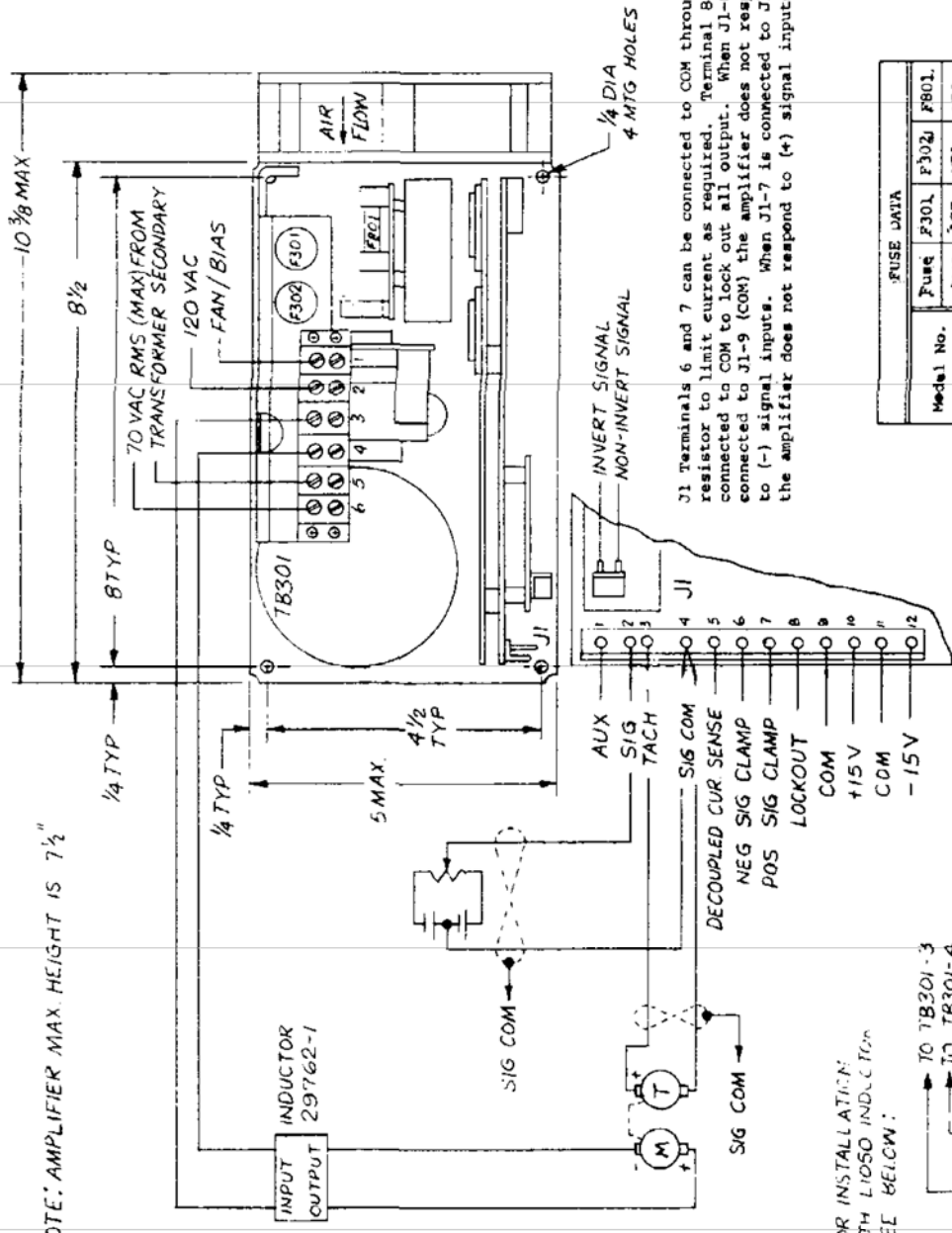

J1 Terminals 6 and 7 can be connected to COM through a resistor to limit current as required. Terminal 8 can be connected to COM to lock out all output. When J1-6 is connected to J1-9 (COM) the amplifier does not respond to (-) signal inputs. When J1-7 is connected to J1-9 (COM), the amplifier does not respond to (+) signal inputs.

FUSE DATA		
Model No.	Fuse Type	F302, F801
A6511-10	1 Amp 20 Amp	5 Amp
A6511-10	1 Amp 20 Amp	5 Amp
A6511-10	1 Amp 20 Amp	5 Amp

RECOMMENDED INSTALLATION PROCEDURE

1. CAUTION: Outputs at TB301 must be isolated from all other circuits and must not be grounded.
2. Use shielded wire on signal input leads, connect shield to Signal Common at J1.
3. Output at TB301-3 is (+) w.r.t. TB301-4 when J1-2 is (+) w.r.t. J1-4 or when Non-Invert signal is (+) w.r.t. Invert Signal.
4. Motor frame and Amplifier chassis must be connected to System Ground. Do not ground Transformer secondary.

FOR INSTALLATION WITH L1050 INDUCTION SEE BELOW:

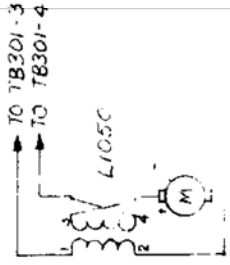

PART NO. 100-1000 QUANTITY 1000 ORDER PARTS TO: 100-1000 112 S. 37TH AVE. LOS ANGELES, CALIF. 90008 SEND RADI. BREAK DOWN ORDER.	DESCRIPTION INSTALLATION DRAWING MODEL A6511	MATERIAL WESTAMP INCORPORATED 1542 15TH STREET SANTA MONICA, CALIF.	LIBR REV A 29999 SHEET 8
DATE 11-11-50	SCALE 7/8	DRW. BY	APP. BY
FINISH		1954	

FIG #2

ADJUSTMENTS:

Figure 3 shows the location of various adjustments on the circuit board. These adjustments are as follows:

Aux Gain - Potentiometer R-2 adjusts the auxiliary gain in the event that this input is used. If this input is not used, the auxiliary potentiometer R-2 should be turned to the fully "ccw" position.

Sig Gain - The signal gain potentiometer R-5 is used to set the signal gain of the system. Turning R-5 in a "cw" direction increases the signal gain.

Tach Gain - The tach gain should be adjusted to set the stability of the tachometer loop, and to adjust the amount of tach feedback in the closed loop system. R-12 is the tach potentiometer. Turning R-12 in a "cw" direction increases the tachometer gain.

Balance - Potentiometer R-23 is the balance control. It may be necessary to adjust the balance for zero output when zero input is applied. This should be done after the tach and signal gains have been adjusted.

TC - The TC (time constant) potentiometer is R-15. The TC potentiometer is used to help stabilize the closed loop system. "CW" rotation increases the bandwidth.

Cur Lim - The current limit potentiometer is R-28. If the current limit potentiometer is at the maximum "cw" position then the unit puts out its maximum rated peak current. If it is desired to decrease the peak output current of the amplifier, turn the Cur Lim potentiometer in a "ccw" direction to reduce the peak output current.

The proper procedure to be followed in setting up this unit in your servo system will be explained in a Short Form Set Up Procedure which follows:

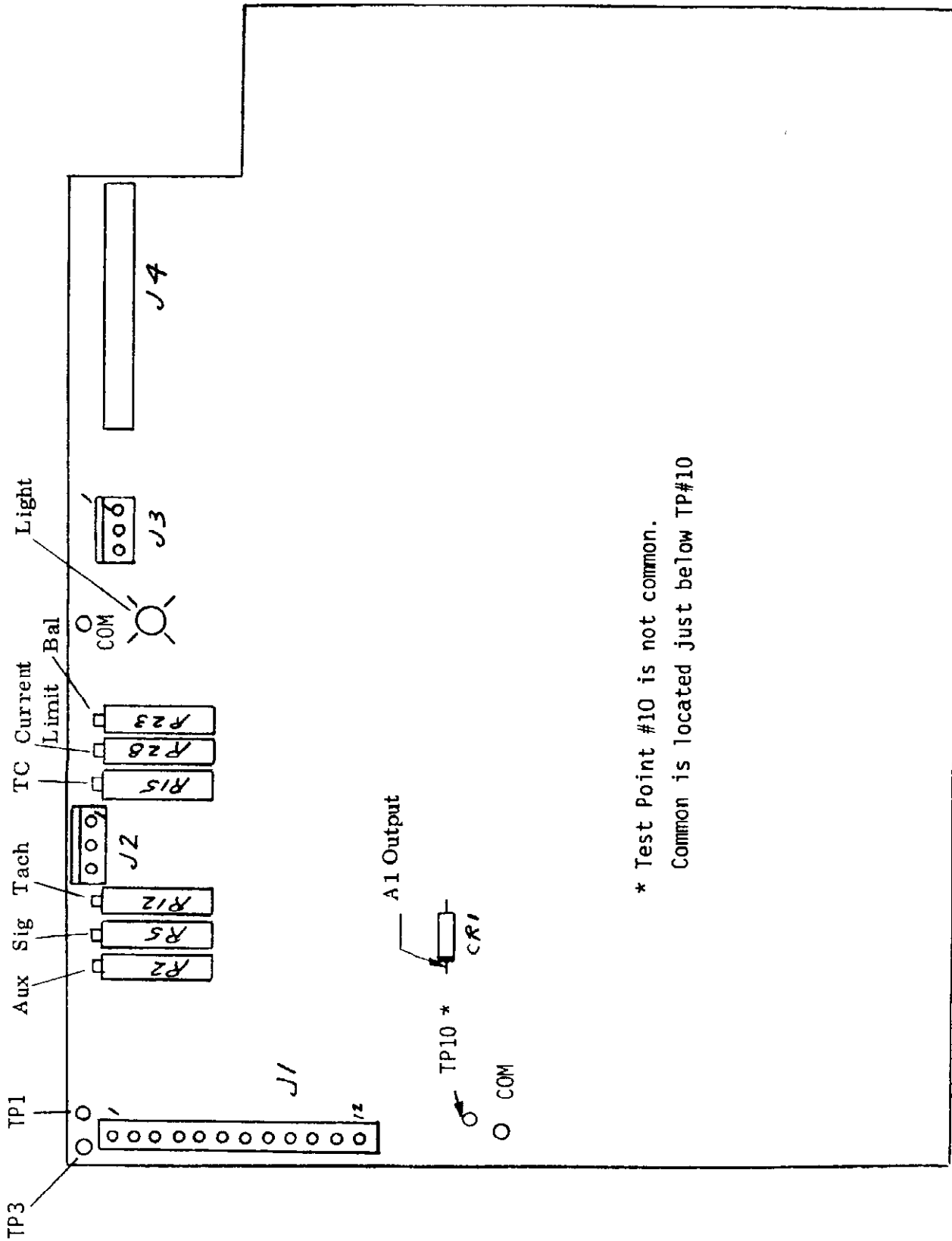

* Test Point #10 is not common.
 Common is located just below TP#10

FIG # 3

SERVO SYSTEM COMPENSATION:

It is possible to compensate a servo system empirically without any theoretical evaluation of the system, provided that the specifications are not too stringent. For most applications, the procedure outlined in the Short Form "Set Up Procedure" will result in adequate servo performance. The A651 Series of servo amplifiers was designed to operate with "state of the art" characteristics in modern performance oriented systems. Therefore, matching amplifier-motor-tachometer combinations are recommended. However, the A651 Series Amplifiers will provide good performance with many DC motor-tach-combinations, by merely adjusting the TC and the tach gain potentiometers.

SHORT FORM SET UP PROCEDURE (All PWM Amplifiers)

1. Check input voltages and proper transformer connections.
2. Make sure you measure the voltages before connecting to amplifier chassis.
3. Connect in accordance with proper installation drawing.

NOTES: All adjustment multiturn pots are nominal.

THE FOLLOWING PROCEDURE IS WRITTEN FOR 20 TURN NOMINAL POTS - - YOU MUST READ THE SECTION IN BACK OF BOOK ON POTS TO VERIFY THE TYPE OF POTS (# OF TURNS) YOUR UNIT HAS.

4. Before turning power on, adjust all pots as follows:
 - a) Current limit pot - fully "ccw"
 - b) "TC" pot - mid range (10 turns from either end)
 - c) Tach pot - turn fully "ccw" then turn "cw" 5 turns
 - d) Signal pot - mid range (10 turns from either end)
5. Apply power but do not apply an input signal
6. To check phasing of the tachometer and motor: turn the current limit pot cw very slowly. If the motor starts to run away, remove and reverse the phase of the motor or tachometer.
7. Turn the power back on and repeat Item 6. (Do not consider drift) Turn current limit pot to desired current.

(CLM pot setting allows amplifier to deliver peak currents) as shown in example:

Example:

<u>20 Turn Pot</u>	<u>12 Turn Pot.</u>
3 turns cw = 30% peak current	1.8 turns cw = 30% peak current
6 turns cw = 60% peak current	3.6 turns cw = 60% peak current
10 turns cw = 85% peak current	6.0 turns cw = 85% peak current
14 turns cw = 95% peak current	8.5 turns cw = 95% peak current

8. If the motor shaft rotates slowly with no signal being applied, adjust the signal balance pot either way until the motor shaft stops.
9. Still with no input signal, turn "TC" pot "cw" until motor shaft starts to oscillate at high frequency, then turn "ccw" until this oscillation stops, then 1/2 additional turn "ccw".
10. IMPORTANT - IF TC IS FULLY CCW & SYSTEM IS STILL OSCILLATING AT HIGH FREQUENCY, SEE NOTES ON PAGE 14.
11. Apply a small signal and observe motor shaft.
12. Increase or decrease tach gain pot for desired results.
 - A) Increasing tach (turning pot cw) provides quicker settling time (higher bandwidth).
 - B) Decrease tach (turning pot ccw) provides slower settling time (lower bandwidth).
13. After you are satisfied with the tach response, do not change the tach pot anymore.
14. If the motor drifts, it may be necessary to re-adjust the signal balance pot.
15. Run the motor at some higher speed and watch and listen to it. If it runs smoothly, the system is OK. A rough sound means either the TC is still too far cw, or TACH is too far cw.
16. Set the appropriate speed of the system by turning the signal gain pot. CW will make the system go faster for the same voltage into the unit.
17. No further adjustments are necessary. (STOP)

MORE DETAILED SET UP PROCEDURE

If your system requires more accurate tach adjustment.

1. Go thru Steps 1-10 on previous pages.
2. Then apply a small signal until motor rotates. Watch the tach signal on an oscilloscope.

NOTE: Refer to Helpful Hints Section.

3. If the tach loop is overdamped, turn the tach pot cw until one overshoot appears. The system is now set up for maximum bandwidth in the tach loop.
4. If you don't want an overshoot in your tach loop, turn the tach pot ccw until the overshoot disappears.

NOTE: One overshoot in the tach loop does not necessarily mean the position loop will overshoot.

5. IF THE SYSTEM IS NOT PERFORMING PROPERLY AND IS MECHANICALLY SOUND, SEE NOTES ON THIS PAGE AT BOTTOM.
6. Also, if motor shaft rotates slowly with no signal input, it may be necessary to re-adjust signal balance pot until motor stops.
7. After you have made the above adjustments, you will have to recalibrate signal gain pot to obtain the proper output voltage to input signal ratio.
8. All other adjustments are factory set and do not require further adjusting.

CAUTION: MAKE SURE POWER IS OFF WHEN SOLDERING ON CIRCUIT BOARDS.

- NOTES:
1. Check system for backlash, wind-up lost motion, misalignment bad coupling or any other mechanical problems.
AFTER YOU MAKE ANY OF THE CHANGES BELOW, REPEAT SET UP PROCEDURE - START WITH STEP 4 ON PAGE 12.
 2. High frequency oscillation even though TC pot is fully ccw (high frequency oscillation probably motor resonance).
Increase C7 to approximately .033 mfd start with TC fully ccw.
It may also be necessary to add C3 = 2 mfd and C5 = .22 mfd.
 3. If system requires more DC gain
 - a) Increase C6 to approximately .1 mfd and decrease R11 to approximately 2K. You might have to increase C7 to approximately .033 mfd - Reference Note 2 above.
- OR
- b) Reduce value of R16 - However, balance adjustment will become more sensitive.
4. If the system is highly inertial, or a highly inertial motor is used, it may be necessary to change C6 and R11 - Reference Note 3a above.

HELPFUL HINTS:

1. Tachometer should be observed on an oscilloscope where sweep speed is set at .1 seconds/centimeter and adjust the vertical attenuator to provide a convenient displacement in response to the signal input.
2. Small step input commands may be provided with a DC simulator (battery box) while observing the tach response on the oscilloscope.
3. Typical pictures you will see on oscilloscope of tach profiles.

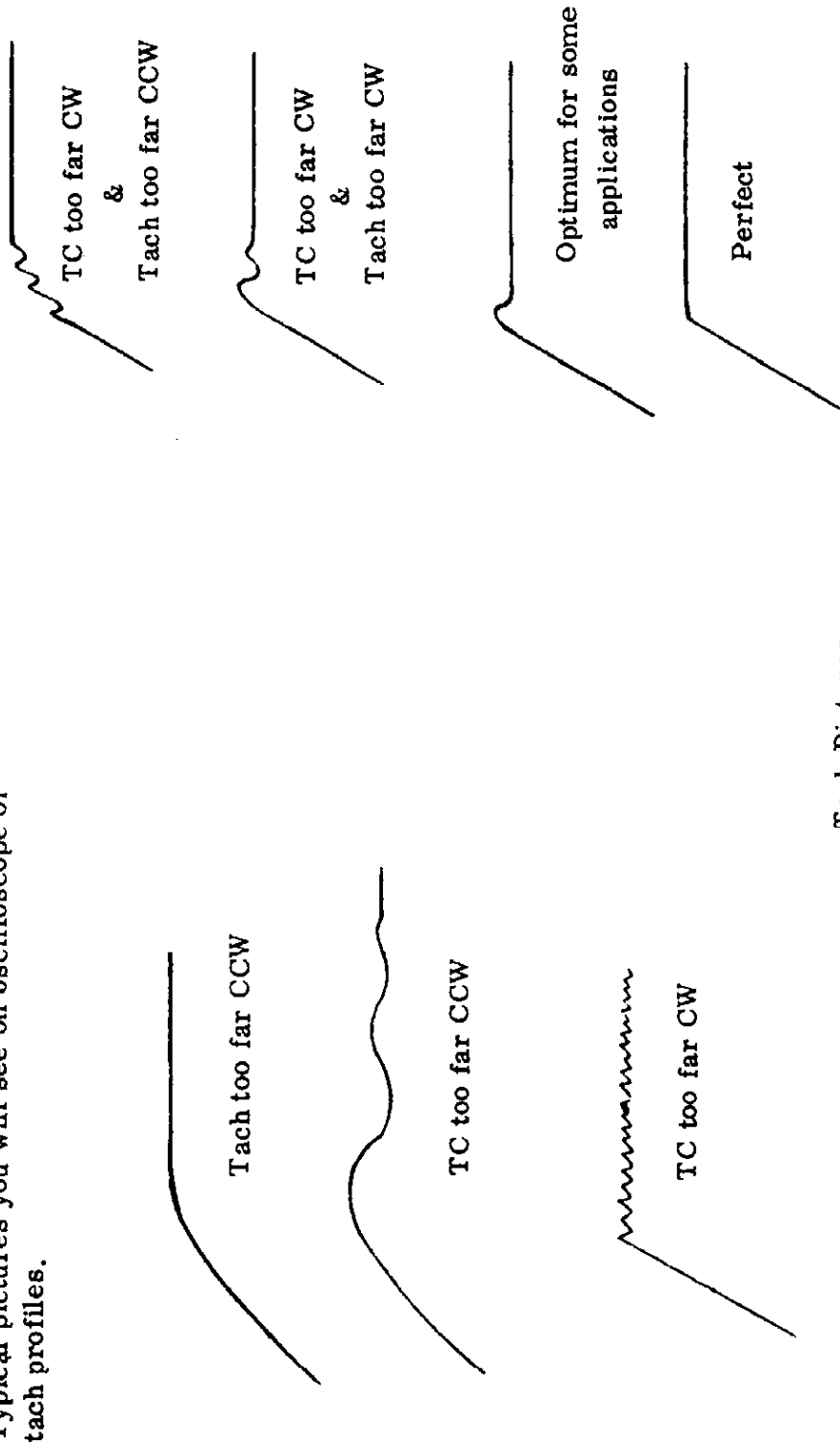

Tach Pictures

TROUBLE SHOOTING AIDS: Ref. Installation Drawing (Fig. 2)
Board Layout (Fig. 3 & 4) & Schematic

In the event that the unit should fail to operate, it is advisable to follow the procedure:

1. Examine the unit visually for loose connections, broken wires, and damaged components.
2. Look and see if fault indicator red light is on. Read over Protective Features and Other Features Sections. Do some checking to find the reason for the trip indication. Don't merely turn power off - wait 15 seconds and re-apply power. There was some reason for fault indicator to be on.

TYPICAL REASONS:

1. Shorts to ground may occur.
 - A) Brushes arcing to the frame of a motor during high speed reversals.
 - B) Motor armatures shorting to case.
 - C) Leads to motor becoming pinched and frayed in the wiring trough and touching ground.
 - D) Faulty wiring of connections.
 - E) Eventually, during the running of any DC motor, brush dust can build up in a motor causing an electrical path from the brushes to the motor case.
2. Check shunt regulator fuse (if unit has one). The fuse could blow due to:
 - A) Excessive regeneration time. (Customer may have changed duty cycle).
 - B) Blown power transistor (s) in shunt regulator.
3. Check the wiring to the motor and tachometer.
4. Improper main bus power voltage coming from the power transformer.
5. Blown input power fuse F-302 or control power fuse F-301.
6. Lack of +15 volts on J1-10 (relative to J1-11).
7. Lack of -15 volts on J1-12 (relative to J1-11).
8. Connect a volt meter across the two terminals on the large capacitor on the chassis to read the bus power supply voltage. If the secondary of the transformer is 48 VAC, you should read about 65 ±15 volts DC across this capacitor.
If AC secondary reads 72 VAC, you should read about 100 ±15 volts DC across this capacitor.
9. If all the fuses and voltages are proper, it is then advisable to determine if an input signal exists. This can be done by looking at J1-2, with respect to signal common.

CAUTION: DO NOT USE GROUNDED TEST EQUIPMENT (FLOAT SCOPE).

If there is a signal voltage at J1-2 check the output of the velocity control amplifier which can be seen at cathode of diode CR-1. It should vary inversely with the input voltage.

10. If still not functioning, it is advisable to return this unit to the factory for repair, since sophisticated test equipment, which is usually not available in the field, is required to determine the cause of failure. It is very easy to remove the control drive module. Simply remove the plugs and loosen the two screws which hold the module to the chassis. These screws should not be completely removed for ease of installation of a new module.

TYPICAL INSTALLATION AND FIELD PROBLEMS - FAULT CONDITIONS

Westamp A651 Series of Drives

<u>PROBLEM DEFINITION</u>	<u>CAUSE</u>	<u>EFFECT</u>	<u>SOLUTION</u>
High bus voltage	Wrong transformer tap Regulator sized incorrectly Regulator fuse blown	Fault trip with indication " "	Correct fault condition, re-set drive " "
Excessive surge currents	Either motor line connected to ground Output leads become shorted together before inductor	" "	" "
Excessive current at high motor speeds	Exceeded safe commutation zone of motor & motor probably arcing to case	"	Re-set drive & re-select appropriate current limit.
Excessive RMS current	Duty cycle increased Stalled motor - shorted motor Shorted motor lines after inductor System oscillation	Drive will shut down and cycle	Correct fault and drive will operate normally.
Over temperature	Clogged or damaged fan Cabinet temp. too high	Fault trip with indication	Improve the cooling.
Low bus voltage	Power line sag Blown line rectifiers	Reduced output voltage "	Drive still operates. Replace line rectifiers.
Incorrect bias power	Overload on bias supplies	Fault trip with indication	Check reason for overload - correct - then replace bias supply fuse.

TO RE-SET DRIVE:

NOTE: Under all conditions where unit shuts off with light indication, it is necessary to remove bias power, wait approximately 15 seconds, then re-apply power. Drive will re-start if fault condition cleared.

TROUBLE SHOOTING

MULTI AXIS DRIVE SECTION ONLY

A6512, 3, 4

Ground Faults

More than one module on a multi axis chassis may show a fault indication if any one axis is shorted to ground. The reason for this is, there is one ground fault detector for the entire chassis.

In order to isolate the faulty axis, sequentially unplug the ± 15 volt supply to each axis. (connector J3). When you have found the axis that is causing the problem by disconnecting its J3 plug, all other modules will function normally.

Other Faults

Faults such as over bus voltage during regeneration, loss or dip of ± 15 volt bias supply may turn one or more modules LED's on.

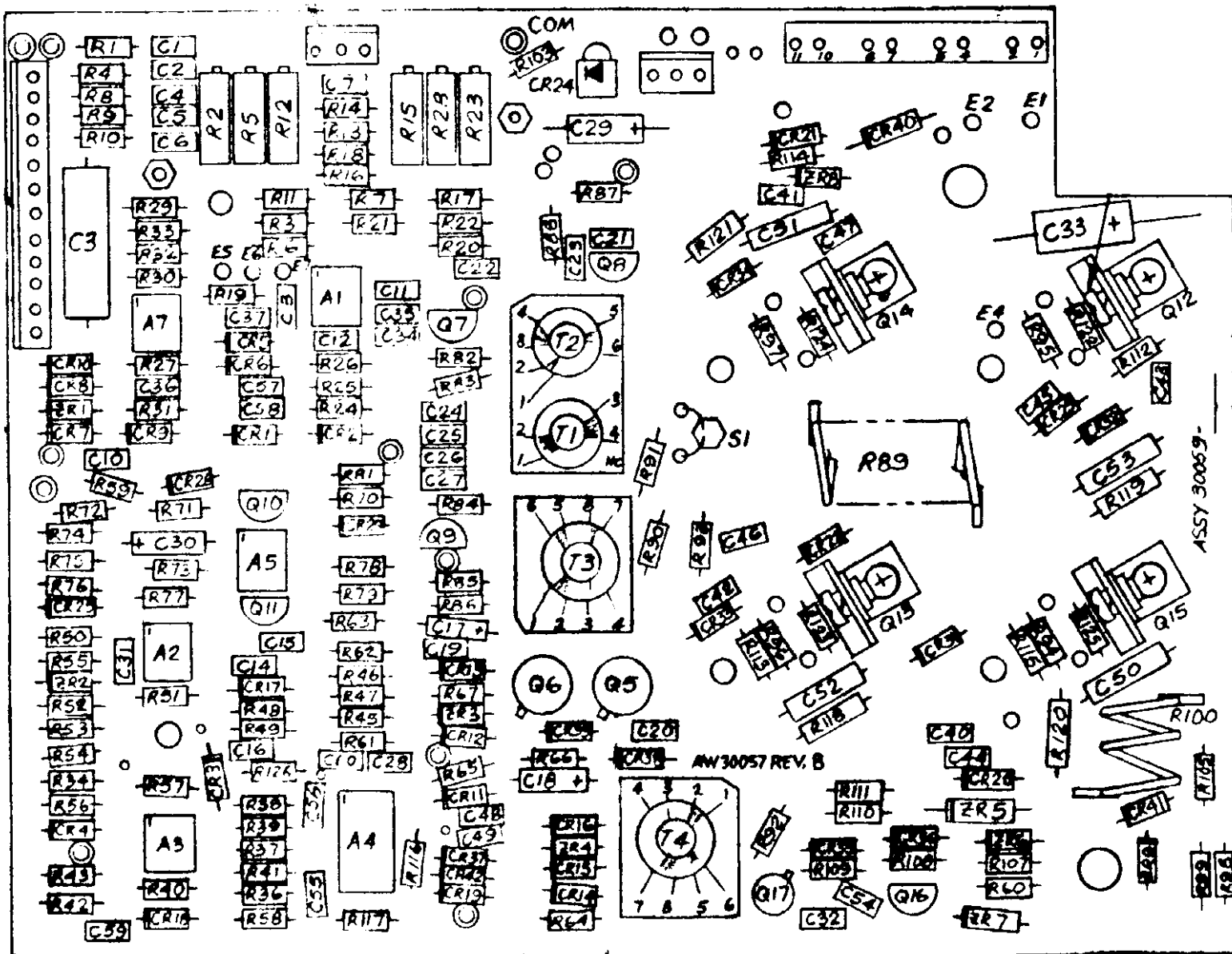
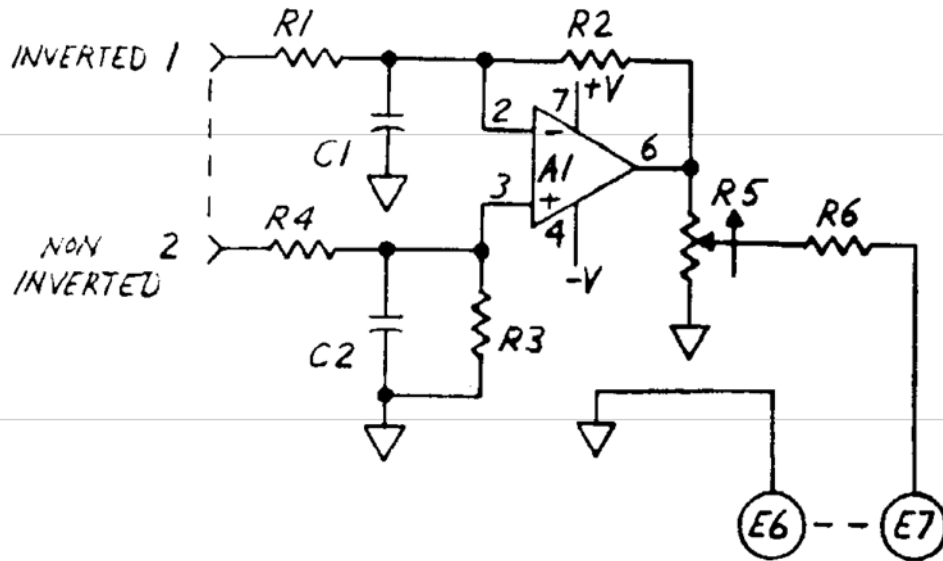
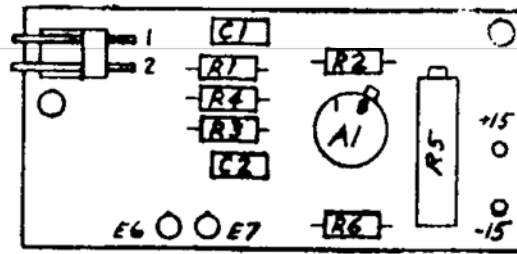

FIG #4



DIFFERENTIAL
INPUT BOARD
ASSEMBLY

OPTIONAL

FIG #5

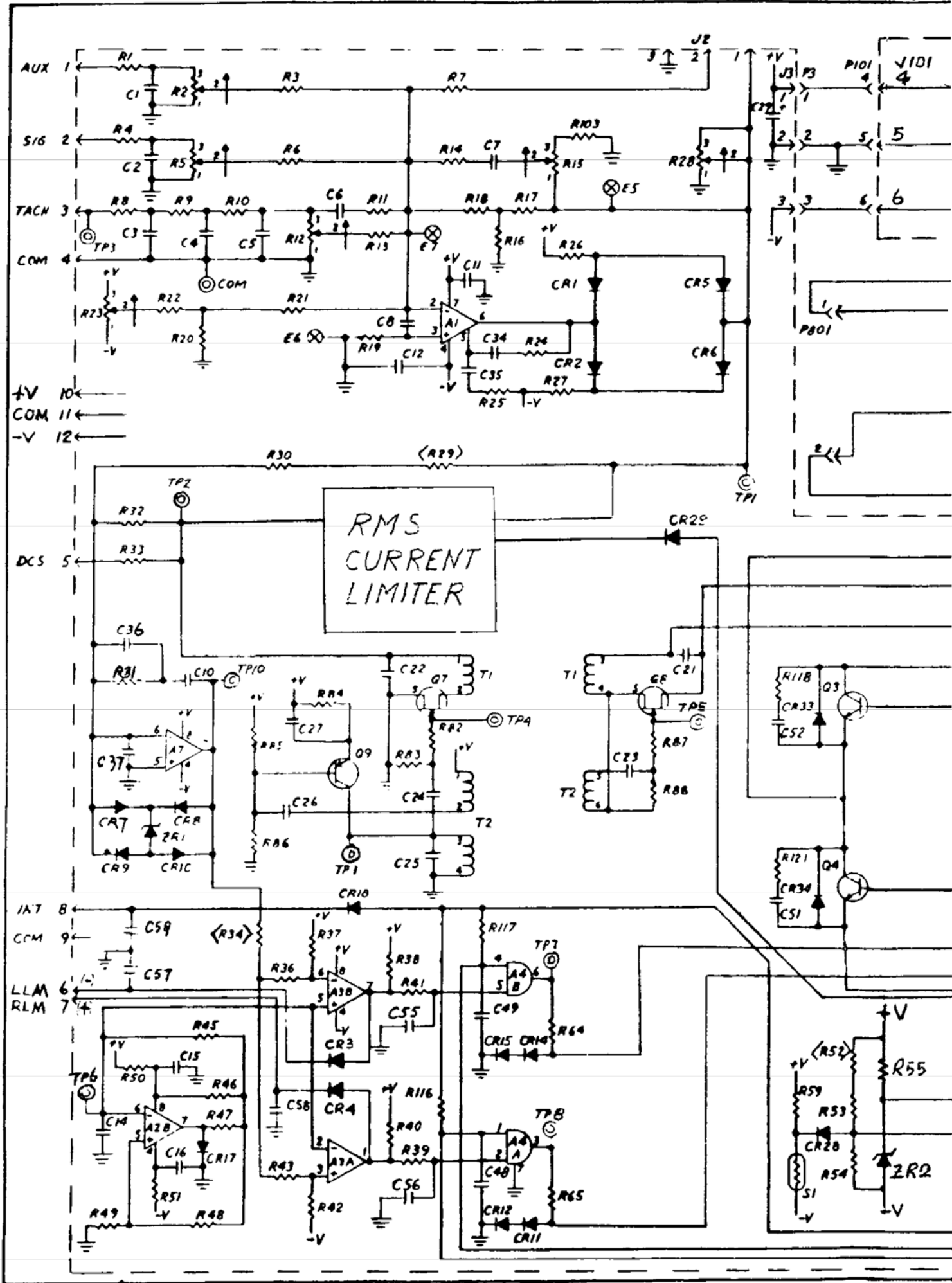

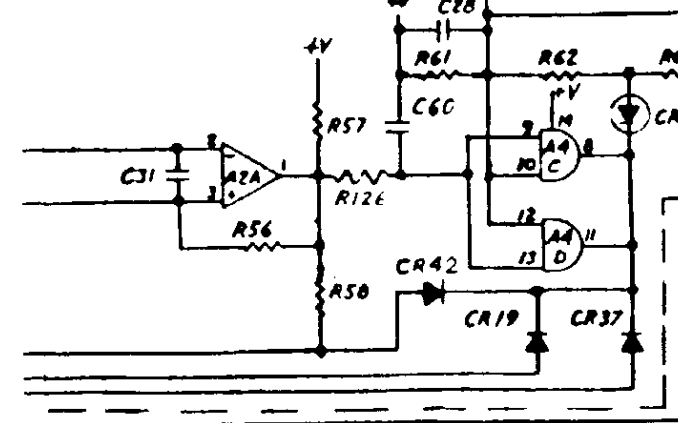
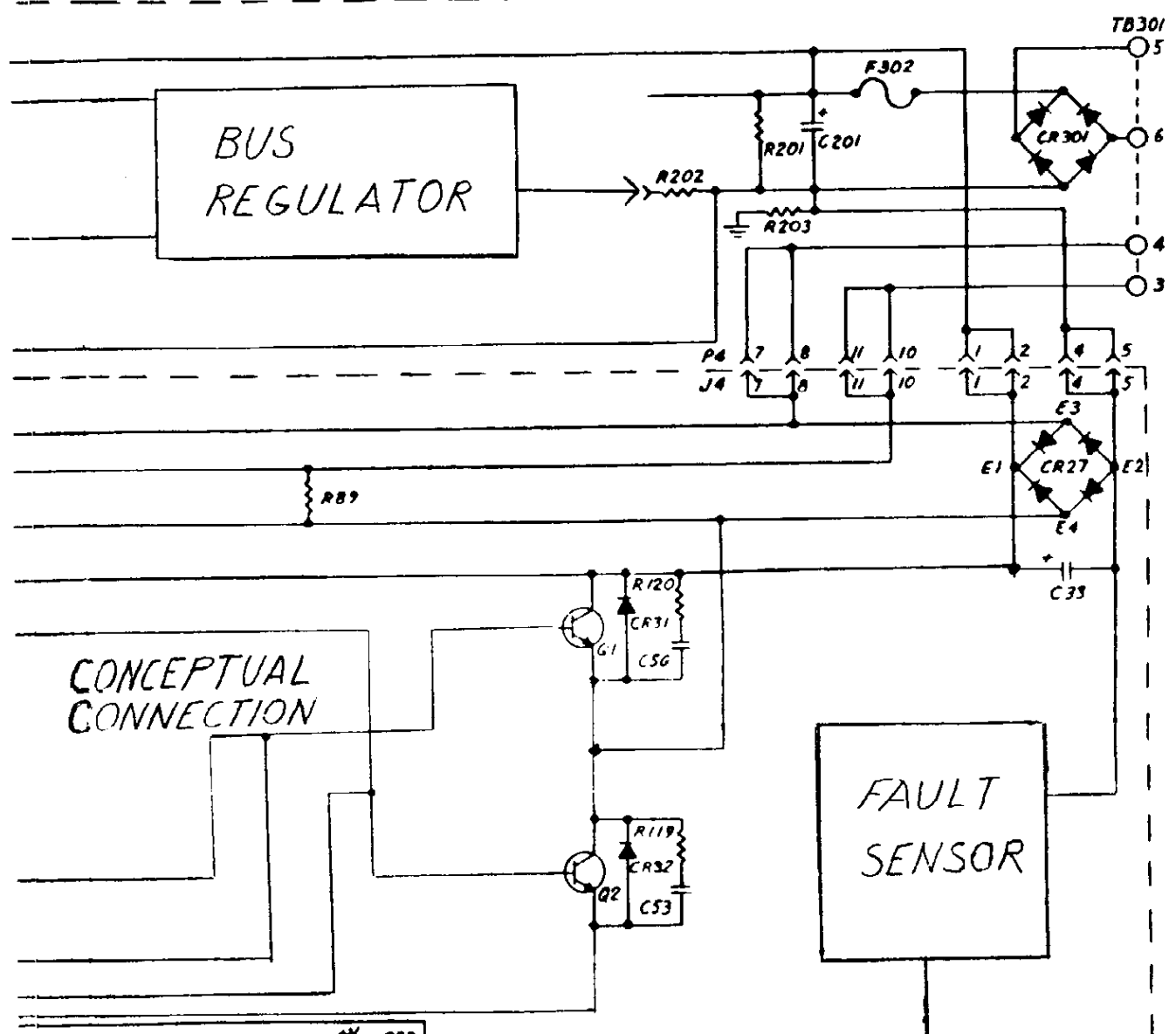
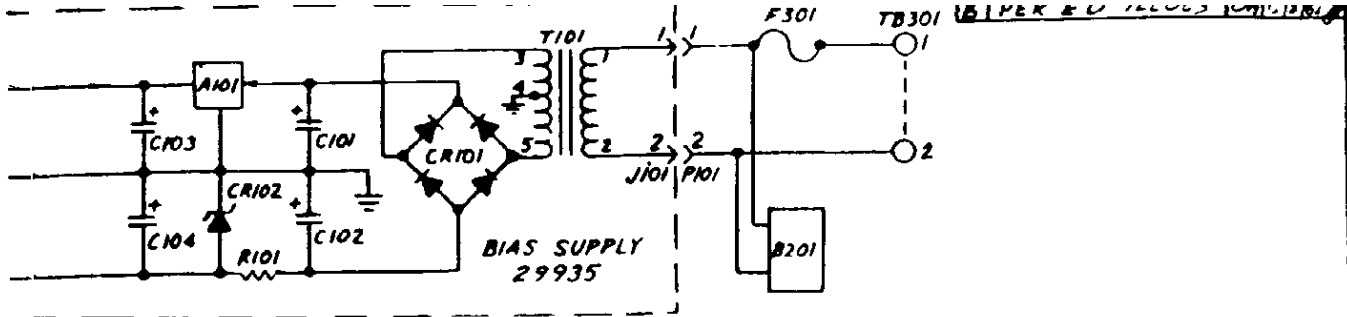

AW 30057 REV. B
30059 CONTROL/DRIVE BOARD

<p>WESIAMR INCORPORATED 1042 18TH STREET SANTA MONICA, CAL.</p>	<p>SYSTEM SCHEMATIC A6511</p>	<p>29927</p>	<p>B</p>
---	---------------------------------------	--------------	----------

MULTI-TURN POTENTIOMETERS

Various manufacturers' potentiometers have been used in the amplifier.

Please refer to the following chart:

MANUFACTURER	POT COLOR	NOMINAL # OF TURNS	OVERTRAVEL DEAD-ZONE
Weston	Light Green	12	0
Beckman	Light Gray	20	0
VRN	Dark Green	20	0
Spectrol	Tan	20	4-5 Turns

Set-up procedures are often established based on counting the number of turns from the counter clockwise end to the set point. Spectrol potentiometers have a 4 to 5 inactive section at the end.

If your amplifier now has a tan Spectrol pot, you must turn the potentiometer adjustment screw 4 to 5 turns from the counter clockwise end before any resistance change will occur.

If your set-up procedure is based on a potentiometer other than Spectrol, please refer to the following to establish your new number of turns.

NUMBER OF TURNS TO CONVERT SET-UP PROCEDURE FOR VARIOUS POTS

ORIGINAL POT WAS	NOW - TAN SPECTROL POT
Light Gray Beckman	$T + 4.5$
Light Green Weston	$1.67 \times T + 4.5$
Dark Green VRN	$T + 4.5$

Where T is the number of turns from counter clockwise to the setpoint originally used for the previously supplied potentiometer.

APPLICATION NOTE

DO YOU REALLY NEED AN INDUCTOR IN SERIES WITH A MOTOR WHICH HAS ENOUGH INDUCTANCE?

The answer to the above question is YES & NO

NO - If the motor is commutating properly

NO - If the motor never develops an internal winding problem

YES - If either of the above problems exist

AND HERE'S WHY

We have found by practical experience that when a motor becomes partially shorted out in some of its windings, the inductance seen by the amplifier will go down below the minimum amount required.

When the inductance goes below this minimum value the peak current the output transistors are required to deliver will be exceeded and the transistors may become damaged.

The sketch below will help describe how this occurs.

Let's use a standard A651-10E which is rated at 22 amps peak and sketch what is really happening to the output transistors.

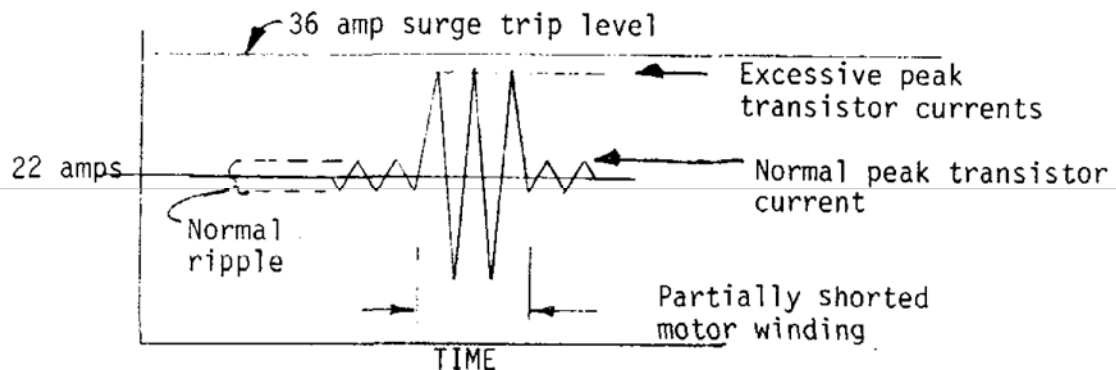

Normal ripple current is 20% peak to peak with the minimum inductor. The sketch is showing how the peak current of 24 amps can be exceeded.

The amplifier is protected against surge currents and the surge current detector is set to sense at or above 36 amps.

However, with reduced inductance, the current can go up to 35.5 amps peak and the amplifiers surge detector cannot sense this current.

So the output transistors will fail since they are being asked to deliver more current than they are capable of for too long of a period of time.



To protect the amplifier under this condition, we recommend an external series inductor and if you still choose not to use one, you now know what can happen - - Field Service calls cost money.

Customer _____

Amplifier Model _____

Machine _____

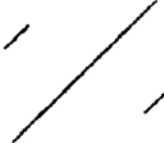
AMPLIFIER SETTINGS

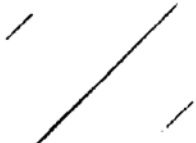
AXIS	EXAMPLE	X	Y	Z
MODULE P/N If Known	A651 Type 22/10 Amp			
POTENTIOMETER SETTINGS FROM FULLY CCW POSITION				
AUX POT	Not Used			
SIGNAL POT	5 Turns			
DIFFERENTIAL INPUT YES/NO	No			
TACH POT	10 Turns			
Tc POT	15 Turns			
CURRENT LIMIT POT	12 Turns			

SPECIAL NOTES:

Here you might want to indicate the overall # of turns of the pots.
See Application Note section on pots.

DATE _____



* You might want to copy this page and put it with the machine.

REVISED FUSE SIZING

Jan. 9, 1985

	<u>FAN</u>	<u>BUSS</u>	<u>SR</u>
	<u>F301</u>	<u>F302</u>	<u>F801</u>
A6511 Single Axis Dwg. 29999 Sht. 4	----- AGC 1 Amp	MDA 20 Amps	MDA 5 Amps
	<u>F401</u>		<u>F801</u>
A6512 Dual Axis Dwg. 29990 Sht. 2	----- MDA 3 Amps		MDA 5 Amps
	<u>F401</u>		<u>F801</u>
A6513 & A6514 Multi Axis Dwg. 29990 Sht. 1	----- MDA 3 Amps		MDA 5 Amps
	<u>F401</u>		<u>F801</u>
A6515 & A6516 Multi Axis Dwg. 32500 Sht. 4	----- MDA 3 Amps		MDA 5 Amps
	<u>F401</u>		<u>F801</u>
A6517 & A6518 Multi Axis Dwg. 32500 Sht. 1	----- MDA 3 Amps		MDA 5 Amps