

INSTRUCTION MANUAL

WESTAMP A 652 SERIES REV.C

This is a general manual describing a whole series of amplifiers and may be used in conjunction with drawings pertaining to various specific models.

CAUTION

The maintenance procedure described herein should be attempted only by highly skilled technicians using proper test equipment. Read your warranty provisions before starting, to avoid voiding your warranty.

TABLE OF CONTENTS

<u>ITEM</u>	<u>PAGE</u>
Forward	1
Fuse Data	1
Drive Specifications (Standard Voltage)	2 & 3
Drive Specifications (High Voltage)	3A
Block Diagram Description	4
Block Diagram	4
Protective Features	5
Other Features	5 & 6
Installation Drawing	7
Adjustments	8
Simplified PC Board Layout	8
Servo Compensation	9 & 10
Helpful Compensation Hints	10
Trouble Shooting Discussion	11
Trouble Shooting Table	12
Circuit Board Layout	13
Drive Schematic	14 & 15

FORWARD:

This manual is a general purpose manual, covering the theory and application of the A652 Series of Pulse Width Modulated Servo Amplifiers.

This manual does not necessarily apply specifically to any individual amplifier. However, the information is presented in a general way so that it may be applied to a specific amplifier in conjunction with its associated drawings.

The A652 Series of Pulse Width Modulated Amplifiers consists of a single chassis which contains the following:

1. A control amplifier board module which contains the control circuits,
2. One or more output power sections which contains the output transistors.
3. The chassis contains the bias power supply which is plus and minus 15 volts, the main output power supply, the terminal block with the input and output connections for the power section, protective fuses, a UL listed blower and regulator.

FUSE DATA			
MODEL NO.	FUSE	F 401	F 801 - 4
	TYPE	AGC	MDX
A6521B - 24B		2	3

SPECIFICATIONS:

HIGH PEAK CURRENT MODELS

	A6521B	A6525	A6522B	A6526		
1.	Peak Current	± 40 A	± 56 A	± 75 A	± 87 A	
2.	Continuous Current	± 22 A	± 32 A	± 40 A	± 48 A	
3.	Peak Voltage (Typ)	± 100 VDC				
4.	Voltage at continuous current (Typ)	± 92 VDC				
5.	HP Rating (Cont)	2.7 HP	4.0 HP	4.9 HP	5.9 HP	
6.	Input Voltage	10 VAC to 70 VAC & (120 VAC RMS at 2 amps)				
7.	Form Factor	1.01 - Defined at full output current				
8.	Switching Frequency	Constant				
9.	Frequency Response	500 Hz Min				
10.	Dead Band	None				
11.	Gain	Adjustable (18 turn pots)				MODEL
	Input 1 (Aux)	0 to 6000 A/V (Min)				
	Input 2 (Signal)	0 to 6000 A/V (Min)				
	Input 3 (Tach)	0 to 6000 A/V (Min)				A6521B
12.	Signal Input Impedance	20 K Min				
13.	Signal Input Voltage					A6522
	Typical	± 10 Volts				
	Max	± 50 Volts				A6523
14.	Drift (Refer to Input)	10 u V/°C				
15.	Current Limit	Adjustable (18 turn pots)				A6525
16.	Signal Balance	Adjustable (18 turn pots)				A6522B
17.	Ambient Temp. (Operating)	0 - 50°C				A6524
18.	Auxiliary Inputs	Gain reduction				
		Limit switch overtravel				A6526
		Remote on - off (electronic)				
		Programmable current limit				A6523B
19.	Auxiliary Outputs	Output current monitor (See Notes)				
		± 15 VDC @ 50 MA				A6527
20.	System Compensation	Adjustable & built in				A6524B
21.	Protection	a) Shorts to ground either leg				
		b) Shorts across output				
		c) RMS overload protection (electronic)				
		d) Bias fault protection				
		e) Overvoltage indication & shut down				
		f) Overtemperature protection				
		g) Current limit				
		h) Bias power fuse				
22.	Cooling	Blower				
23.	Weight	9 lbs - Model A6524B without power transformer or inductor,				
24.	Mounting	Panel (Vertical/Horizontal)				
25.	Power Transformer	Separate. May be supplied by customer, if desired.				
26.	Options	Regulator				
		Special compensation				
		Tapered current limit - for reduced current at high output voltages (motor commutation capability)				

HIGH CONTINUOUS CURRENT MODELS

A6523B	A6527	A6524B	A6522	A6523	A6524
± 100 A ± 57 A	± 110 A ± 65 A	± 120 A ± 75 A	± 40 A ± 30 A	± 56 A ± 45 A	± 75 A ± 60 A
7.0 HP	8.0 HP	9.0 HP	3.7 HP	5.5 HP	7.4 HP

SERIES INDUCTORS

Minimum
mHy

- 4
- 4
- 2.7
- 2.7
- 2.2
- 2.2
- 1.8
- 1.7
- 1.5
- 1.3

NOTES:

1. Maximum peak current is for 500 msec.
2. Frequency response is typical of units with no compensation. System compensation in most applications usually reduce the response.
3. Consult the factory concerning applications requiring continuous regeneration.
4. 120 VAC is for blower and bias power.
5. Output voltage max is from 70 VAC RMS bus power.
6. Unit provides a range of output voltages depending on input voltages.
7. Output current monitor is capable of driving a zero center 100 micro ampere meter.
8. If red light is on, this indicates trip of fault logic. Remove power - wait 10 seconds - re-apply power. Unit will re-start if fault has cleared.

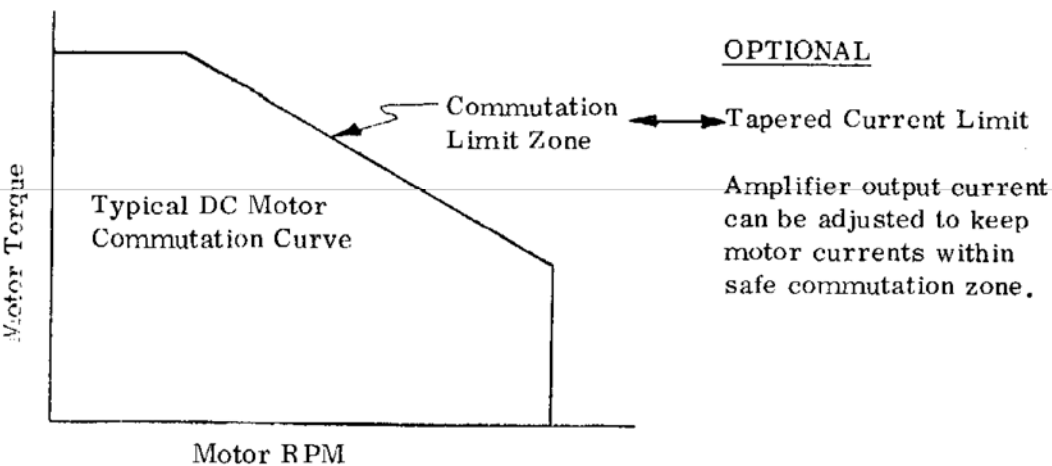

HIGH VOLTAGE MODELS - A652X - 16E

HIGH PEAK CURRENT MODELS

HIGH CONTINUOUS CURRENT MODELS

	<u>A6521B</u>	<u>A6525</u>	<u>A6522B</u>	<u>A6526</u>	<u>A6523B</u>	<u>A6527</u>	<u>A6524B</u>	<u>A6522</u>	<u>A6523</u>	<u>A6524</u>
1. PEAK CURRENT	26	36	50	57	65	70	78	26	36	50
2. CONTINUOUS CURRENT	14	20	26	30	37	42	49	20	30	40
3. PEAK VOLTAGE (Typ)	160									
4. CONT. VOLTAGE (Typ)	152									
5. H.P.	2.9	4.0	5.3	6.0	7.5	8.5	10	4.0	6.0	8.0
6. INPUT VOLTAGE	(10 VAC to 115 VAC) and (120 VAC RMS at 2 AMPS) BUSS VOLTAGE) and (BIAS VOLTAGE)									

MIN SERIES
INDUCTANCE MHY

8.8	6.4	4.6	4	3.5	3.3	3	8.8	6.4	4.6
-----	-----	-----	---	-----	-----	---	-----	-----	-----

NOTE:

IN MANUAL WHERE 72 VAC IS REFERENCE
FOR BRIDGE POWER USE 115 VAC.

BLOCK DIAGRAM DESCRIPTION:

The A652 Series of D,C, Servo Amplifiers are transistorized pulse width modulated units. The following description and explanation of the Block Diagram of this model is presented, so that you may have a better understanding of the operation of this unit: See Fig No. 1

There are three inputs for this unit.

1. Auxiliary Input.
2. Signal Input.
3. Tachometer Input.

Each of the inputs has a potentiometer which is used to adjust the effective gain of that input. The three input signals are summed in the velocity control amplifier which also contains the necessary compensation for achieving servo stability. The output of the velocity control amplifier is directed to the input of the current error amplifier. There is also a current feedback input to the current error amplifier from the current sensor. The current error amplifier amplifies the difference between the current command and current feedback signals. The output of the current error amplifier is fed to the modulator where it is summed with the output from the triangle waveform generator. The modulator takes these two signals and converts them to a pulse width modulated output. The output of the modulator is then fed to the fault gate which permits the modulator output signal to proceed to the driver amplifier when there are no faults.

In the event of a fault (such as low bias voltage, or a short from either side of the output to ground, or a short across the output, or an overvoltage on the output bus) the fault gate closes and shuts the amplifier off. The output of the fault gate is connected to the driver amplifiers which drive the output bridge. The output of this bridge is connected directly to the motor.

A current sensing resistor is in series with the output of the bridge which senses the output current. The current sensor generates an output voltage proportional to the output bridge current. This voltage signal is then fed to the delayed current limit circuit and is also used as a feedback signal for the current error amplifier. In the event that the output current exceeds the rated R.M.S. current of the unit, the delayed current limit circuit reduces the output current to the safe operating level for this unit.

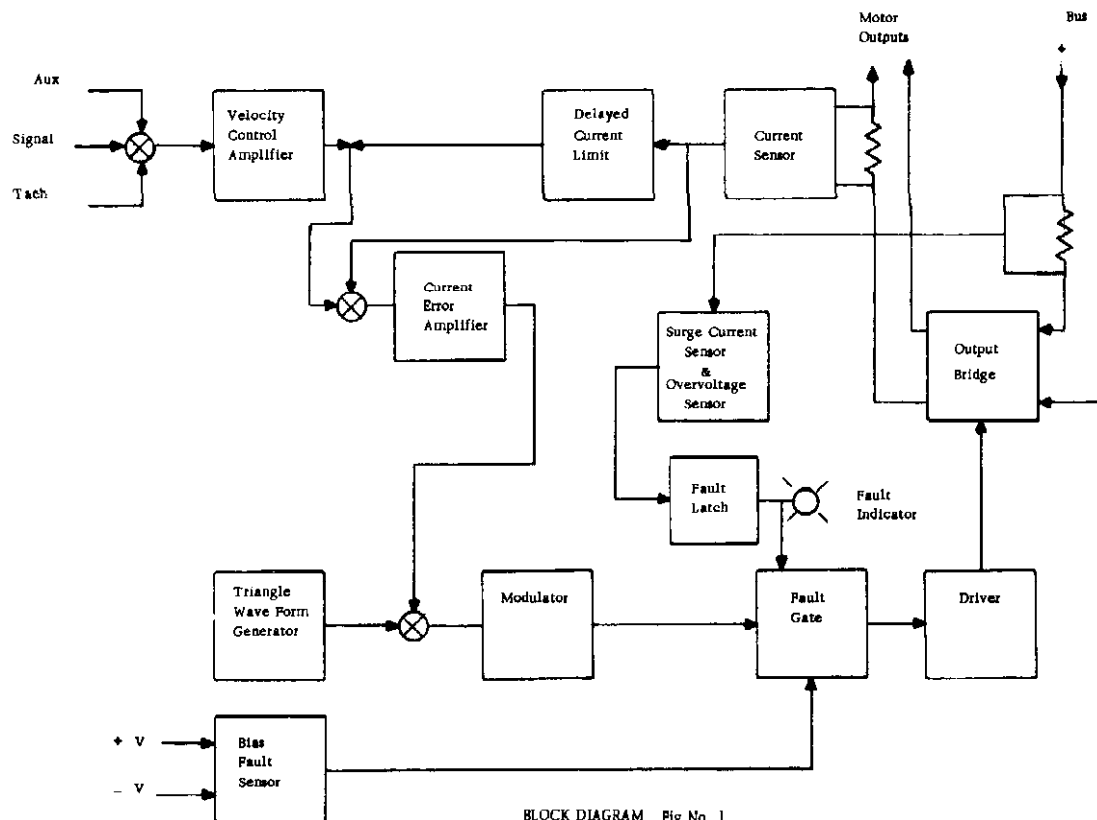

BLOCK DIAGRAM Fig No. 1

PROTECTIVE FEATURES:

The A652 unit has the most advanced safety features available today in the marketplace.

These safety features help protect personnel, machinery and the amplifier from accidental damage.

- A) Amplifier will shut off and turn on red fault light if:
- 1) Motor short of either side of armature to ground with or without use of external inductor.
 - 2) Output of amplifier should be inadvertently shorted - only before inductor, or if no external inductor is used.
 - 3) If power supply voltage exceeds safe level of amplifier due to regeneration of motor.
 - 4) Overheating of unit.
- B) Amplifier will not shut off, but is protected for the following:
- 1) Output of amplifier shorted after external inductor.
 - 2) Low input bus voltage down to 0 volts.
 - 3) Low input bias voltage down to 75% of 120 VAC.
 - 4) Excessive R.M.S. current under normal operation and oscillatory conditions. Amplifier will put out reduced power and return automatically to full power so as to keep unit within rating.
- C) Amplifier will shut off with no light indication:
- 1) If bias power falls below 75% of 120 VAC.
 - 2) If the sum of bias power is less than approx 28 volts. The unit will remain off until the sum of the bias power ± 15 Volts D.C. are within proper range.

NOTE: Under all conditions where unit shuts off with light indication, it is necessary to remove bias power, wait approximately 15 seconds, then re-apply power.

OTHER FEATURES: Fig No. 3

Connector J-1

Pin 1 - Signal Input (Auxiliary)

Pin 2 - Signal Input (Standard)

Pin 3 - Signal Input (Tach)

Pin 4 - Signal Common

Pin 5 Decoupled Current Sense - The output current of the amplifier is decoupled thru a mod/demod circuit. The demodulator output is applied to this pin and is capable of driving a zero center 100 micro amp meter. Proper scaling of this output current is done by installing appropriate resistors in series with the amp meter. Pin 4 or 9 can be used as return.

Pin 6 & 7 - Limit Switch Overtravel:

These circuits are used to prevent the amplifier from producing more than 12% of rated current when grounded to Pin #9 usually used in conjunction with machine limit switches.

Pin 6 Clamps the negative output.

Pin 7 Clamps the positive output.

Outputs are with respect to signal commands.

- Pin 8 - Electronic shut down and trip indication -
 The bridge drive is disabled by grounding the interlock line, Pin 8. However, if a fault occurs, the line will fall from + 15 volts to 0 volts (50 K ohm maximum external load).
 The point can be used both as an electronic shut down and trip indication, provided proper logic techniques are used.
- Pin 9 - Common for Pins 6, 7 & 8.
- Pin 10 - + 15 VDC bias power.
 50 MA is available for external use.
- Pin 11 - Common bias power.
- Pin 12 - - 15 VDC bias power.
 50 MA is available for external use.

NOTE: Pins 10, 11, 12 - - If more than 50 MA is taken from these pins the bias power will sag and the amplifier may turn off. Reference Paragraphs B and C under Protective Features.

Connector J-2

Pin 1 and Pin 2 may be connected together to reduce gain around velocity control amplifier when jumper installed gain of amplifier becomes 0 to 8 A/V.

Pin 1 and Pin 3 are used for an external programmable current limit by installing an appropriate resistor for the desired current.

Supplement A - APPLICABLE ONLY IF A13 IN MAIN CIRCUIT BOARD

J4 This supplement provides information to control the output drive of the amplifier.
 Pins 1, 3, and 4 of J4 are grounded to Signal Common for normal operation. Pin 1, when grounded to Signal Common, provides output drive in either direction.

Pin 3 controls the Right Drive (RDR) whose output at TB402-5 is positive with respect to TB402-4. If pin 3 is removed from ground, the Right Drive is disabled and only the Left Drive (LDR) is available.

Pin 4 controls the Left Drive whose output at TB402-4 is positive with respect to TB402-5. If pin 4 is removed from ground, the Left Drive is disabled and only the Right Drive is available.

Pin 2 is low, (zero voltage) during normal operation. If a fault should occur, (such as output grounded or low bus voltage) the red light on the control board turns on and the voltage at pin 2 becomes high (+ 15 Volts). This voltage may be used to turn on another red light at a central location to indicate a fault.

Power Supply Regulator (Shunt Regulator)

During the slowing down or stopping of a D.C. motor, the motor regenerates. This energy is put back into the system. The system absorbs this in the form of pumping up the supply voltage capacitor.

If the supply voltage exceeds the set trip level of the overvoltage sensor, the fault sensor trips the unit off and the red light comes on.

In order to keep the voltage on the capacitor within a safe level, it may be necessary to install a regulator. The regulator is protected against excessive dissipation by means of a fuse.

INSTALLATION:

Each amplifier in the A652 Series comes with an individual installation drawing showing where to make the various connections for power input, signal input, tachometer input, fan and bias power input and output to the motor. While this manual may show in a general way how to make connections to amplifiers, it is imperative that the specific instructions applicable to your amplifier are followed. Always be certain to apply the correct input power voltage and frequency. The input power transformer for all the amplifiers in the A652 Series are separately mounted. It is possible to use one power transformer for several amplifier units if that transformer is sized properly. These transformers may have dual voltage primaries and, in such cases, make certain that the jumpers are on the correct transformer terminals for your input AC power source. On all amplifiers the motor output is taken from separate terminals mounted on TB-402.

CAUTION: DO NOT USE GROUNDED TEST EQUIPMENT ON THE OUTPUT CIRCUITS AND DO NOT CONNECT EITHER OF THE OUTPUTS TO GROUND.

The signal input is usually applied directly to Pin 2 of J-1 and the signal common is usually applied to Pin 3 of J-1. The tachometer signal is usually applied to Pin 3 of J-1 and the tachometer return is connected to Pin 4 of J-1. The auxiliary signal is applied to Pin 1 and the auxiliary signal return is applied to Pin 4.

Use shielded wires for signal and tachometer inputs to prevent stray pickup and noise being introduced into the amplifier. The amplifier may have a bandwidth anywhere from 500 Hz (no compensation) to a much lower frequency, depending upon the setting of the TC (time constant) potentiometer and the components in the servo compensation network. Figure 2 shows a typical installation drawing that could be used to test an amplifier-motor combination.

In many cases, a reactor is connected to series with the output of the amplifier and the motor. This reactor is required if the inductance of the motor is below recommended value - See Specification Sheet, Page 2 & 3. The amplifiers in this series require up to 2 amperes of 120 VAC for the fan and power bias which are Terminals 1 and 2 of TB-401. In addition, the output voltage from the secondary of the transformer may be anywhere from 10 volt RMS to 70 volt RMS in accordance with the maximum output voltage required. The output of the secondary of the 3Ø power transformer is connected to Terminals 1, 2, & 3 of TB-402. Please be sure that all the connections are proper before applying power to the unit.

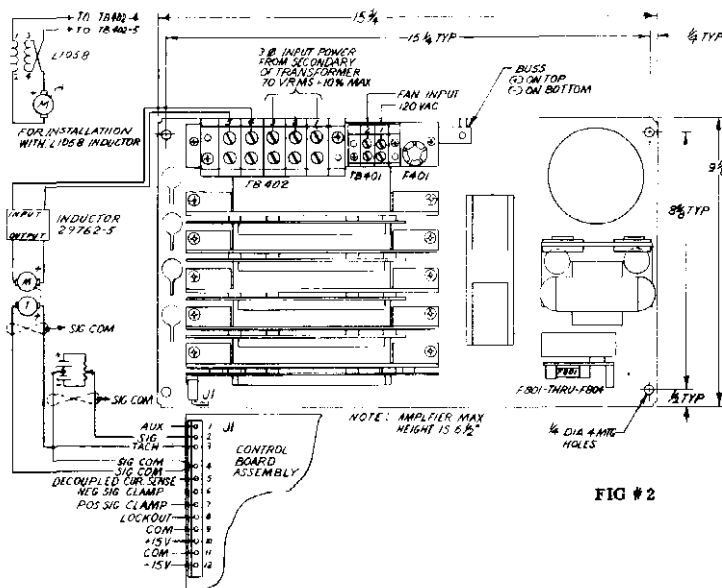

FIG #2

ADJUSTMENTS:

Figure 3 shows the location of various adjustments on the circuit board. These adjustments are as follows:

Aux Gain - Potentiometer R-2 adjusts the auxiliary gain in the event that this input is used. If this input is not used, the auxiliary potentiometer R-2 should be turned to the fully "ccw" position.

Sig Gain - The signal gain potentiometer R-5 is used to set the signal gain of the system. Turning R-5 in a "cw" direction increases the signal gain.

Tach Gain - The tach gain should be adjusted to set the stability of the tachometer loop, and to adjust the amount of tach feedback in the closed loop system. R-12 is the tach potentiometer. Turning R-12 in a "cw" direction increases the tachometer gain.

Balance - Potentiometer R-23 is the balance control. It may be necessary to adjust the balance for zero output when zero input is applied. This should be done after the tach and signal gains have been adjusted.

TC - The TC (time constant) potentiometer is R-15. The TC potentiometer is used to help stabilize the closed loop system. "CW" rotation increases the bandwidth.

Cur Lim - The current limit potentiometer is R-28. If the current limit potentiometer is at the maximum "cw" position then the unit puts out its maximum rated peak current. If it is desired to decrease the peak output current of the amplifier, turn the Cur Lim potentiometer in a "ccw" direction to reduce the peak output current.

The proper procedure to be followed in setting up this unit in your servo system will be explained in a Short Form Set Up Procedure which follows:

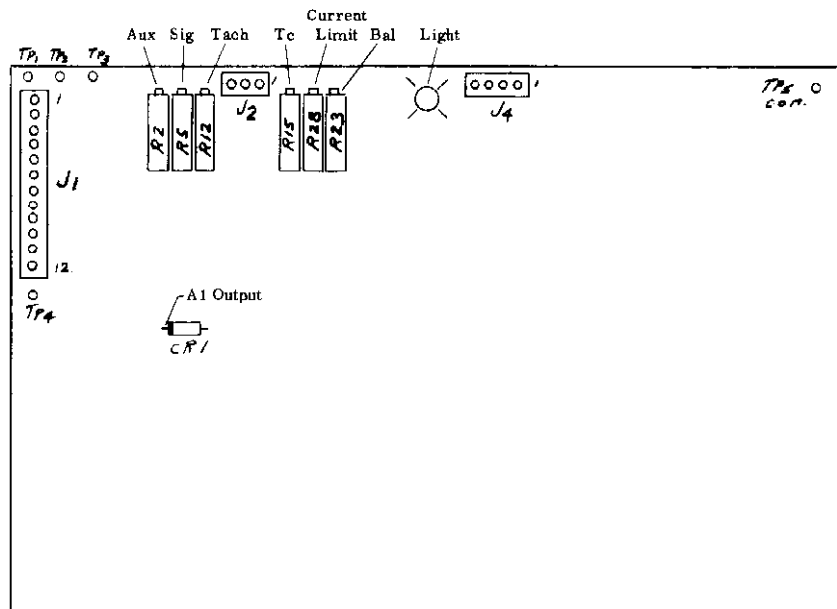

FIG #3

SERVO SYSTEM COMPENSATION:

It is possible to compensate a servo system empirically without any theoretical evaluation of the system, provided that the specifications are not too stringent. For most applications, the procedure as outlined in the Short Form "Set Up Procedure" will result in adequate servo performance. The A652 Series of servo amplifiers were designed to operate with "state of the art" characteristics in modern performance oriented systems. Therefore, matching amplifier-motor-tachometer combinations are recommended. However, the A652 Series amplifiers will provide good performance with many D, C, motor-tach combinations, accomplished by merely adjusting the TC and the tach gain potentiometers.

SHORT FORM SET UP PROCEDURE

(All PWM Amplifiers)

1. Connect in accordance with proper Installation Drawing.
2. Check input voltage and proper transformer connections.
3. Note: All adjustment pots are 18 turns. (Nominal)
4. Before turning power on, adjust all pots as follows:
 - a. Current limit pot - ccw all the way out.
 - b. "TC" pot - mid-range 9 turns from either end.
 - c. Tach pot - turn fully "ccw" then turn "cw" 5 turns.
 - d. Signal gain pot - turn approximately mid-range, 9 turns from either end.
5. Apply power but do not apply an input signal.
6. To check phasing of the tachometer and motor: turn current limit pot cw very slowly. If motor starts to run away, remove power and correct phasing of the motor-tach combinations.
7. Turn power back on and repeat Item 6. (Do not consider drift) Turn current limit pot to desired current.
Pot setting produces currents as shown in example.
Example:
3 turns cw ~ 33% Peak current
6 turns cw ~ 66% Peak current
9 turns cw ~ 85% Peak current
13 turns cw ~ 96% Peak current
8. If motor rotates slowly or drifts, adjust signal balance pot either way until motor stops moving.
9. Still with no input signal, turn "TC" pot "cw" until motor starts to oscillate high frequency, then back off ccw until this oscillation stops.
10. IMPORTANT-IF TC IS FULLY CCW & SYSTEM IS STILL OSCILLATING AT HIGH FREQ, SEE NOTES ON PAGE 10.
11. Apply a small signal and observe motor shaft.
12. Increase or decrease tach gain pot for desired results.
 - A) Increasing tach (turn pot cw) provides quicker settling time (higher bandwidth).
 - B) Decrease tach (turn pot ccw) provides slower settling time (lower bandwidth).Note: Settling time is not to be confused with accel or decel time but is the time just before stopping.
13. After you are satisfied with tach response do not change the tach pot anymore.
14. If motor drifts, it may be necessary to re-adjust signal balance pot.
15. Run the motor at some higher speed and watch and listen to it. If it runs smoothly, the system is OK.
A rough sound means either TC is still too far cw or tach is too far cw.
16. Set the appropriate speed of the system by turning signal gain pot. CW will make system go faster for same voltage into unit.
17. No further adjustments are necessary. (STOP)

MORE DETAILED SET UP PROCEDURE

If your system requires more accurate tach adjustment,

- 1) Go thru Steps 1 - 10,
- 2) Then apply a small signal until motor rotates and watch tach signal on an oscilloscope,
Note: Refer to Helpful Hints section.
- 3) If tach loop is overdamped, turn tach pot cw until one overshoot appears. The system is now set up for maximum bandwidth in tach loop. Tach can be observed on TP-3. Use TP-5 as common.
- 4) If you don't want an overshoot in your tach loop, turn tach pot ccw until the overshoot disappears.
Note: One overshoot in tach loop does not necessarily mean the position loop will overshoot.
- 5) IF THE SYSTEM IS NOT PERFORMING PROPERLY YET AND IS MECHANICALLY SOUND, SEE NOTES ON PAGE 9.
- 6) Also, if motor drifts, it may be necessary to re-adjust signal balance pot until motor stops.
- 7) After you have made the above adjustments, you will have to re-calibrate signal gain pot to obtain proper output voltage to input signal.
- 8) All other adjustments are factory set and do not require any further adjusting.

CAUTION: MAKE SURE POWER IS OFF WHEN SOLDERING ON CIRCUIT BOARDS.

NOTES:

- 1) Check system for backlash, wind up lost motion, misalignment, bad coupling or any other mechanical problems.
AFTER YOU MAKE ANY OF THE CHANGES BELOW, REPEAT SET UP PROCEDURE - START WITH STEP 4 ON PAGE 9.
- 2) High frequency oscillation even though TC pot fully ccw (high freq. oscillation probably motor resonance). Increase C7 to approximately .033 mfd & add C3 = 2 mfd & C5 = .022 mfd.
- 3) If system requires more DC gain then increase C6 to approximately .1 mfd & decrease R11 to approximately 2K. You might have to increase C7 to approximately .033 mfd - Reference Note 2 above.
- 4) If the system is highly inertial, or a highly inertial motor is used, it may be necessary to change C6 & R11 - Reference Note 3 above.

HELPFUL HINTS:

1. Tachometer should be observed on an oscilloscope where sweep speed is set at .1 seconds/centimeter and adjust the vertical attenuator to provide a convenient displacement in response to the signal input.
2. Small step input commands may be provided with a DC simulator (battery box) while observing the tach response on the oscilloscope.
3. Typical pictures you will see on oscilloscope of tach profiles.

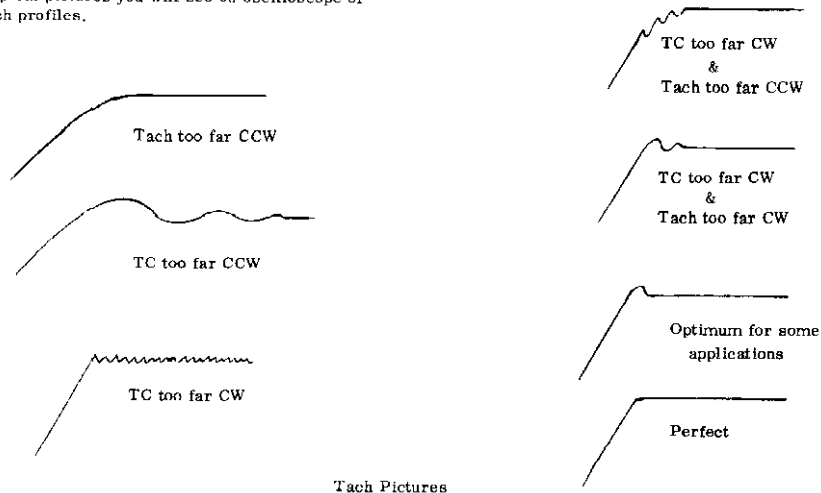

TROUBLE SHOOTING AIDS: Ref, Fig No, 3 and Installation Drawing Fig No, 2

In the event that the unit should fail to operate, it is advisable to follow the following procedure:

- 1) Examine the unit visually for loose connections, broken wires, and damaged components.
- 2) Look and see if fault indicator red light is on. Read over Protective Features & Other Features sections.

Then do some checking to find out reason for trip indication. Don't merely turn power off - wait 15 seconds and re-apply power. There was some reason for fault indicator to be on.

OTHER TYPICAL REASONS:

- 1) Shorts to ground may occur.
 - A) Commutators arcing to the frame of a motor during high speed reversals.
 - B) Motor armatures shorting to case.
 - C) Leads to motor becoming pinched and frayed in the wiring trough and touching ground.
 - D) Faulty wiring of connections.
 - E) Eventually, during the running of any D.C. motor, brush dust can build up in a motor causing an electrical path from the brushes to the motor case.
- 2) Check shunt regulator fuse F801 - F804 (if unit has one). Fuse could blow due to:
 - A) Excessive regeneration time, (Customer may have changed duty cycle).
 - B) Blown power transistor (s) in shunt regulator. (Discussed in Other Features section).
- 3) Check the wiring to the motor tachometer.
- 4) Check the incoming bias voltage, as well as the main bus power voltage coming from the power transformer.
- 5) Check control power fuse F-401 .
- 6) Connect a D, C. volt meter to Pin 10 of J-1 with the common lead on Pin 11 of J-1 and check for plus 15 volts.
- 7) Connect the D.C. volt meter to Pin 12 of J-1 with the common lead on Pin 11 of J-1 and check for minus 15 volts.
- 8) Connect the volt meter across the two terminals on the large capacitor on the chassis to read the bus power supply voltage. If the secondary of the transformer is 48 volts, you should read about 65 ± 5 volts D, C. If the AC output voltage of the transformer is around 70 volts, you should read about 100 ± 5 volts D.C. across this capacitor.
- 9) If all the fuses and voltages are proper, it is then advisable to determine if an input signal exists.
 - A) If you are putting command signal into (Aux) Input #1 look at TP-1
 - B) If signal in (Sig) Input #2 look at TP-2.
 - C) Use TP-5 as common.

CAUTION: DO NOT USE GROUNDED TEST EQUIPMENT (FLOAT SCOPE)

If there is a signal voltage at TP-1 or TP-2 check the output of the velocity control amplifier which can be seen at cathode of diode CR-1.

- 10) If unit has a damaged power section, this section can be isolated by removing all sections. Then insert one at a time until red light comes on. The last section inserted is probably damaged. The current limit is automatically adjusted for the total number of power sections.

Note: When performing Step #10 it is advisable to check at relatively low current so as to not get a false trip due to incorrect inductor sizing for various amplifier ratings - See Specification Sheet, Page 2 & 3.

- 11) If unit still is not functioning, it is advisable to return this unit to the factory for repair, since sophisticated test equipment, which is usually not available in the field, is required to determine the cause of failure.

TYPICAL INSTALLATION AND FIELD PROBLEMS - FAULT CONDITIONS ONLY

Westamp A652 Series of Drives

<u>PROBLEM DEFINITION</u>	<u>CAUSE</u>	<u>EFFECT</u>	<u>SOLUTION</u>
High bus voltage	Wrong transformer tap Insufficient bus capacitor or regulator sized incorrectly Regulator fuse (s) blown	Fault trip with indication " "	Correct fault condition, re-set drive. " "
Excessive surge currents	Either motor line connected to ground Output leads become shorted together before inductor	" "	" "
Excessive current at high motor speeds	Exceeded safe commutation zone of motor & motor arcing probably to case of motor	"	Re-set drive and re-select appropriate tapered current limit.
Excessive RMS current	Duty cycle increased Stalled motor - shorted motor Shorted motor lines System oscillation	Drive will shut down and cycle	Correct fault and drive will operate normally.
Over temperature	Clogged or damaged fan Cabinet temp. too high	Fault trip with indication	Correct fault condition and re-set drive.
Low bus voltage	Power line sag Blown line rectifiers	Reduced output voltage "	Drive still operates. Replace line rectifiers - drive still OK.
Incorrect bias power	Overload on bias supplies or Shorted bias supplies	Drive will shut off with no damage to output transistors	Check reason for overload - correct - then replace bias supply fuse.

TO RE-SET DRIVE:

NOTE: Under all conditions where unit shuts off with light indication, it is necessary to remove bias power, wait approximately 15 seconds, then re-apply power. Drive will re-start if fault condition cleared.

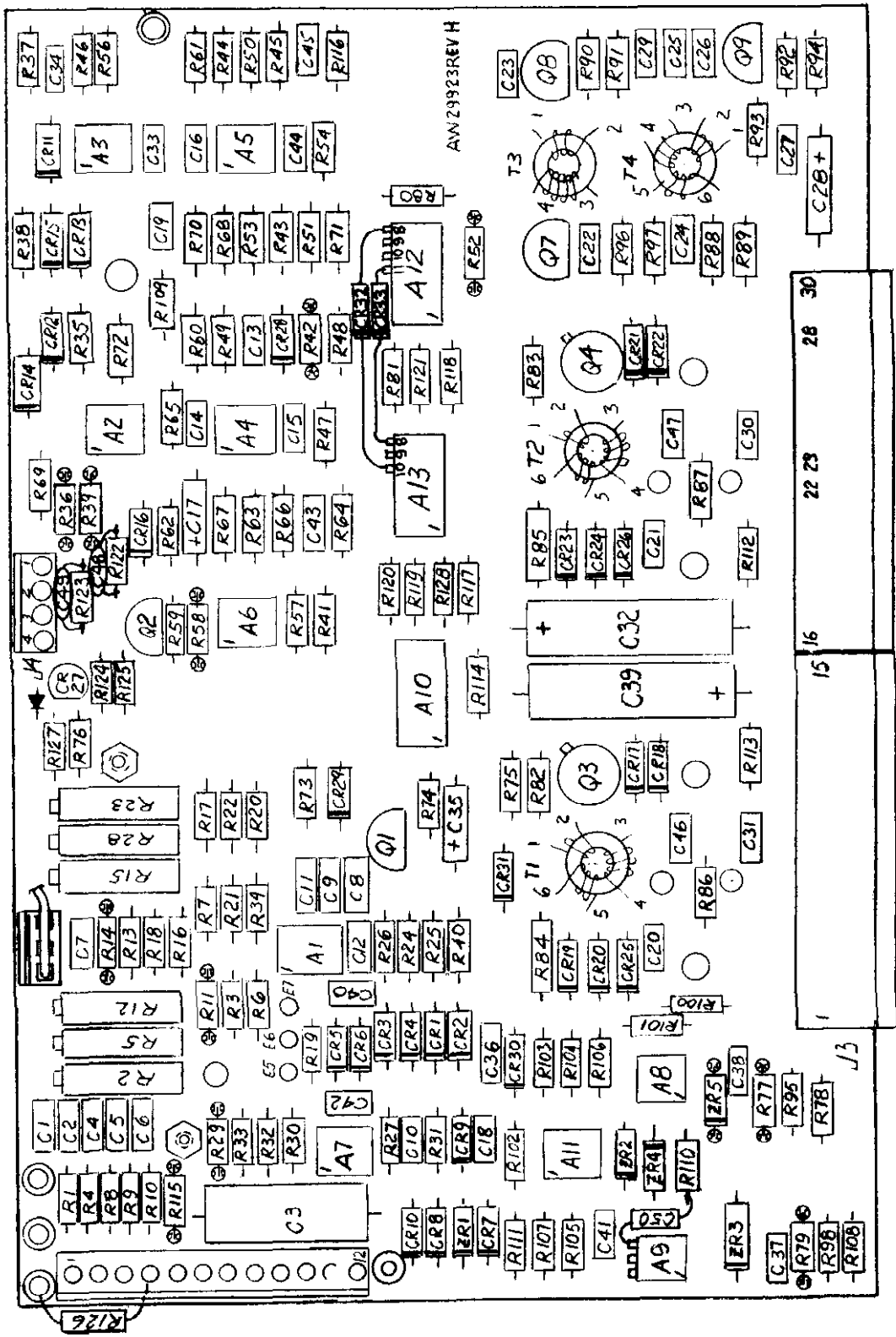

PC BOARD LAYOUT - Fig #4

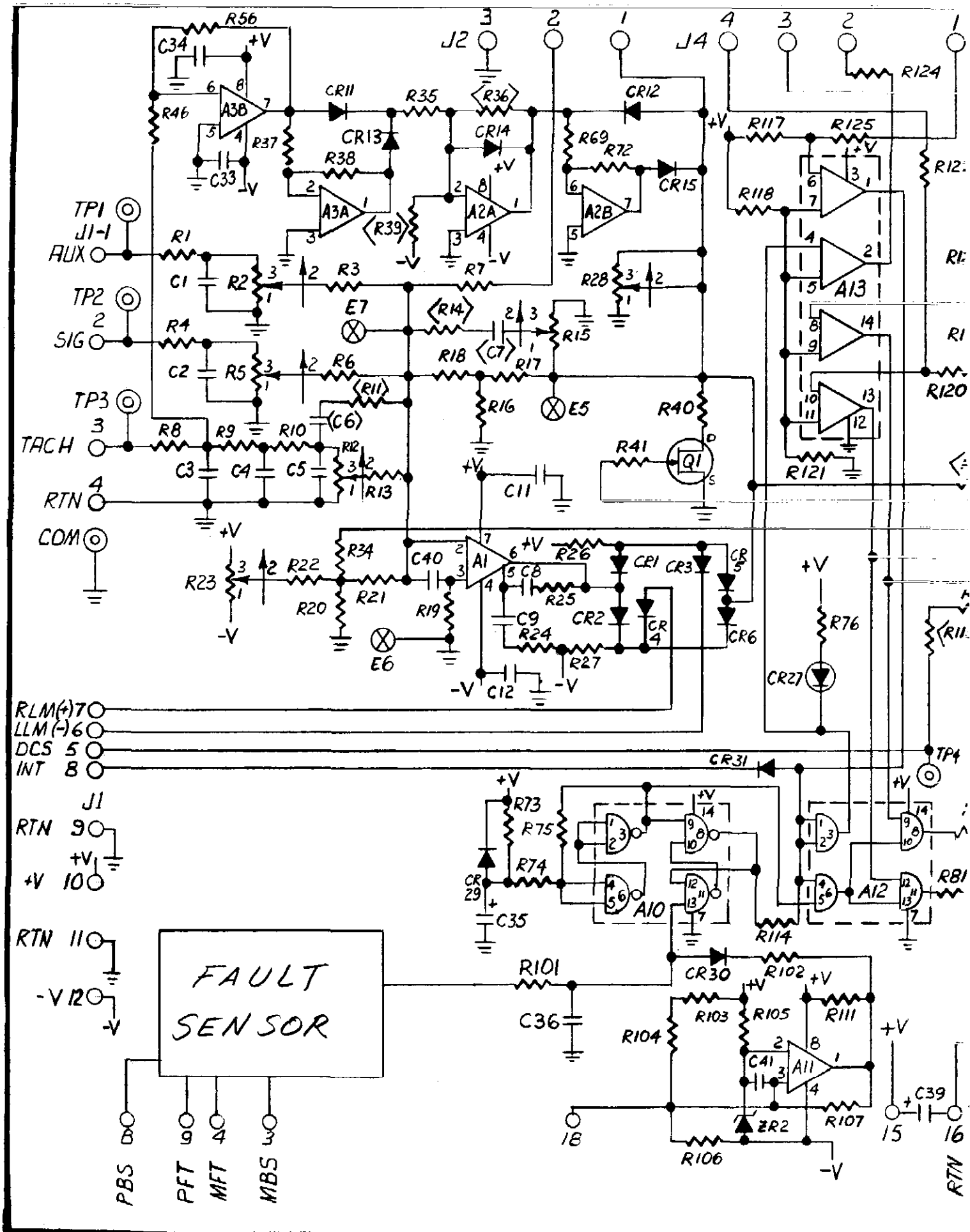

REV. NO.	DESCRIPTION	BY	DATE/APP.

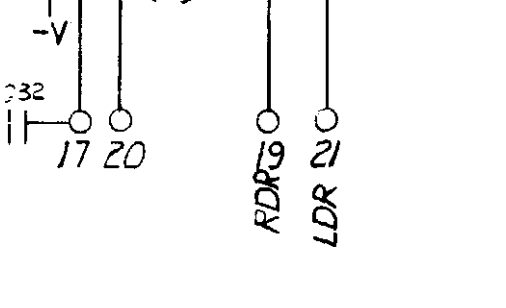
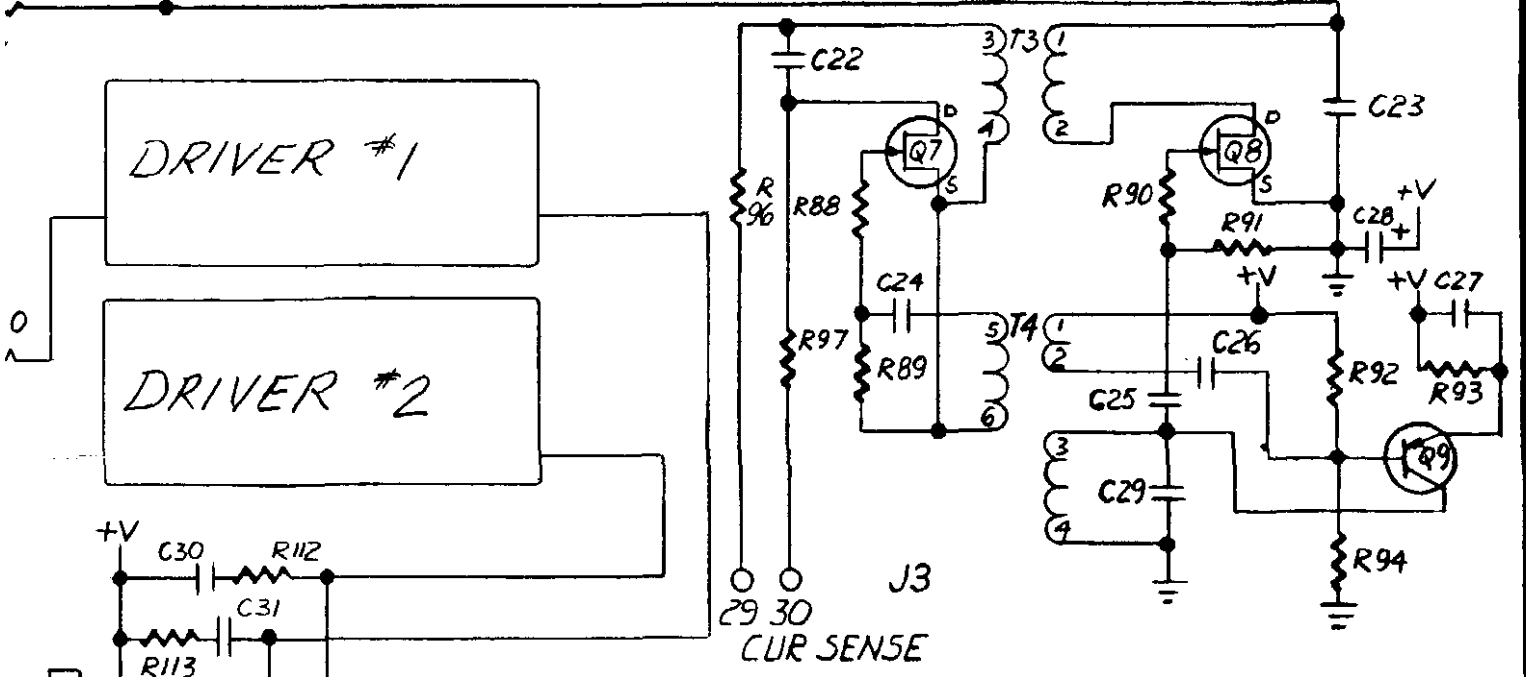
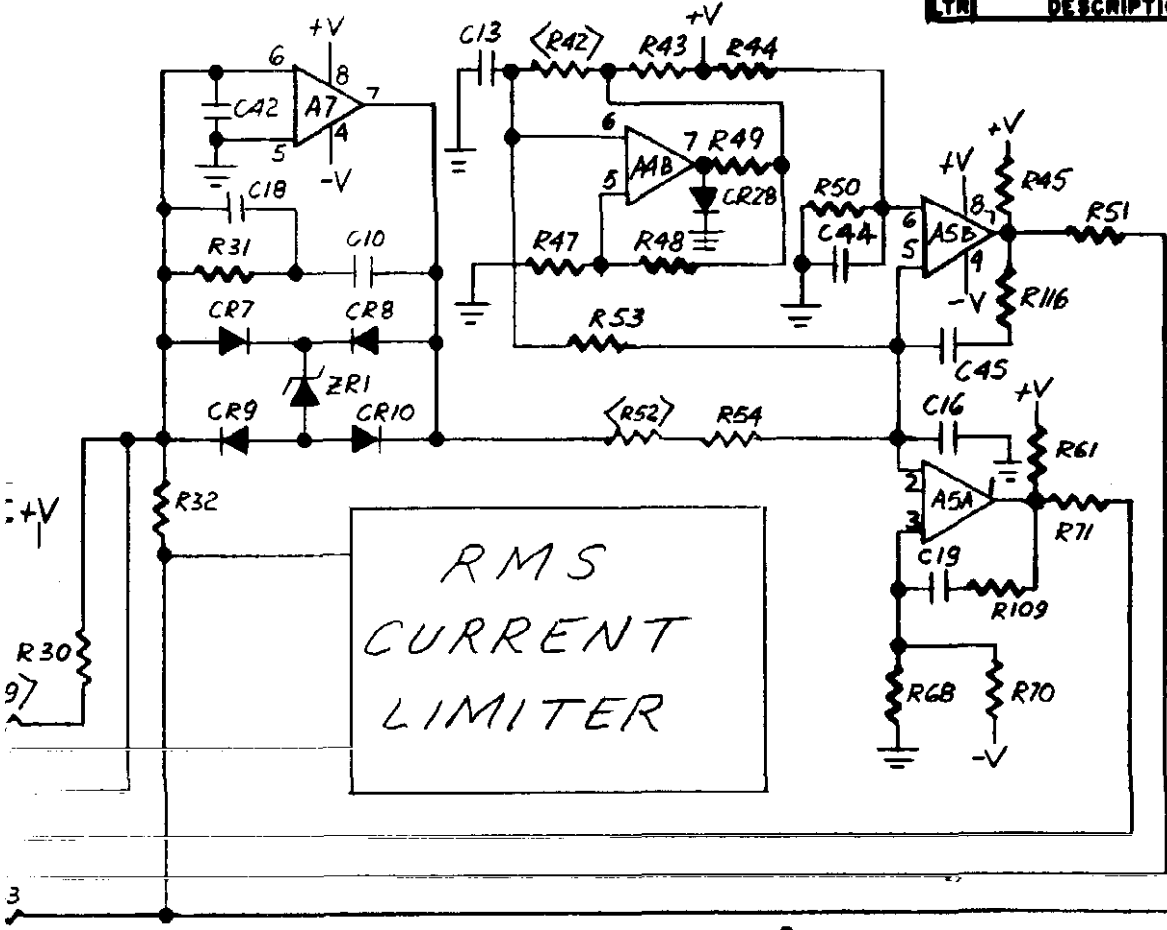

PART NO.	DESCRIPTION	MATERIAL	ITEM
UNLESS OTHERWISE SPECIFIED: TOLERANCES: FRACTIONS ± 3/64 .XX ± .03. XX ± .010 ANGLES 25° BEND RADIUS BREAK SHARP EDGES .005 ± .010			
SCHEMATIC CONTROL BOARD		WESTAMP INCORPORATED 1542 15TH STREET SANTA MONICA, CAL.	
MODEL A652X		SWG NO.	REV.
DATE	SCALE	SHEET OF	