

**INSTRUCTION MANUAL**

**FOR THE**

**A722x<sup>(R)</sup> SERIES**

**DC SERVO AMPLIFIER**

**REVISION C    DATE: AUGUST 7, 1988**

THIS IS A GENERAL MANUAL DESCRIBING A WHOLE SERIES OF AMPLIFIERS AND MAY BE USED IN CONJUNCTION WITH DRAWINGS PERTAINING TO VARIOUS MODELS

**CAUTION**

THE MAINTENANCE PROCEDURE DESCRIBED HEREIN SHOULD BE ATTEMPTED ONLY BY HIGHLY TRAINED TECHNICIANS USING PROPER TEST EQUIPMENT. READ YOUR WARRANTY PROVISIONS BEFORE STARTING, TO AVOID VOIDING YOUR WARRANTY.

**WESTAMP<sup>(R)</sup>, INC.**

1542 15TH STREET  
SANTA MONICA, CA 90404  
(310) 393-0401  
FAX # (310) 451-1058

CONTENTS

	<u>PAGE</u>
WARRANTY/FOREWORD	3
FEATURES	4
SPECIFICATIONS	7
THEORY OF OPERATION	9
PROTECTION FEATURES/CONNECTORS FUNCTIONS	10
POWER SUPPLY/SHUNT REGULATOR	13
INSTALLATION PROCEDURE	14
ADJUSTMENTS	15
DETAILED SET-UP PROCEDURE	17
RESISTANCE MEASUREMENT SET-UP PROCEDURE	18
RMS CURRENT ADJUSTMENT	19
TROUBLESHOOTING	19
TYPICAL INSTALLATION AND FIELD PROBLEMS	21
AMPLIFIER FINAL SETTINGS	22
<u>APPENDIX A</u>	
BLOCK DIAGRAM	A1
INSTALLATION DRAWINGS	A2
HELPFUL HINTS	A7
SIMPLIFIED BOARD LAYOUTS	A8
CONTROL BOARD ASSEMBLY	A9
COMPENSATION BOARD ASSEMBLIES	A10
SCHEMATIC-CONTROL/DRIVE	A12

## WARRANTY PROVISIONS

WARRANTY - The Seller warrants that the article delivered will be free from defects in material and workmanship under normal use and service. Seller's obligations under this warranty are limited to replacing or repairing, at its option, at its factory, any of said articles which shall within one (1) year after shipment be returned to the seller's factory of origin, transportation charges prepaid, and which are, after examination, disclosed to the seller's satisfaction to be thus defective. THIS WARRANTY IS EXPRESSED IN LIEU OF ALL OTHER WARRANTIES, EXPRESSED OR IMPLIED, INCLUDING THE IMPLIED WARRANTY OF FITNESS FOR A PARTICULAR PURPOSE, AND OF ALL OTHER OBLIGATION OR LIABILITIES ON THE SELLER'S PART. FURTHERMORE, THE SELLER NEITHER ASSUMES NOR AUTHORIZES ANY OTHER PERSON TO ASSUME FOR THE SELLER ANY OTHER LIABILITIES IN CONNECTION WITH THE SALE OF SAID ARTICLES.

This warranty shall not apply to any of such articles which shall have been repaired or altered, except by Seller, or which have been subject to misuse, negligence or accident. The aforementioned provisions do not extend the original warranty period of any article which has either been repaired or replaced by the Seller.

## FOREWORD

This is a general purpose manual, covering the theory, operation and application of the A722 Series of DC PWM Servo Amplifiers.

Each A722 (R) pulse-width modulated servo amplifier consists of:

- A. The Servo Drive Module which consists of:
  - 1. Control/drive circuit board
  - 2. Optional compensation board
  - 3. Output transistor heatsink assembly
- B. The main chassis which consists of:
  - 1. Blower
  - 2. Chassis plate
- C. The power Supply Module which consists of :
  - 1. Logic power supply,  $\pm 12.0$  VDC
  - 2. Bus power supply
  - 3. Power I/O terminal block
  - 4. Protective fusing
  - 5. Soft start & Shunt regulator circuitry

## IMPORTANT

When !Caution! is seen in this text, something is being described to avoid possible damage.

A722 FEATURES

Auxiliary Inputs:

- \* 1. Remote Enable/Disable
- \* 2. A Overtravel Limit Switch
- \* 3. B Overtravel Limit Switch
- 4. External Reset
- 5. Signal (AUX)
- 6. Remote Programmable Current Limit (Optional)

\* LED Indication

---

AUXILIARY OUTPUTS:

- 1. Current Monitor ( $\pm 3$  A/V)
  - 2. + 12 VDC
  - 3. - 12 VDC
  - 4. Common
  - 5. Fault
- 

PROTECTION:

- \* 1. Motor shorts to ground
- \* 2. Logic low voltage
- \* 3. Bus over-voltage
- \* 4. Outputs shorted together
- \* 5. Peak current limit
- \* 6. RMS current limit
- \* 7. Overtemperature
- 8. Fuse
- 9. Shunt Regulator

\* LED Indication

---

AVAILABLE CUSTOMER ADJUSTMENTS:

- 1. Signal gain (SIG)
- 2. Signal Balance (BAL)
- \*\*3. Aux. Signal Gain (AUX)
- \*\*4. Tachometer Gain (TACH)
- \*\*5. Time Constant (TC)
- \*\*6. Peak Current Limit (CLM)
- \*\*7. RMS Current Limit
- \*\*8. Adjustable tapered output current inversely proportional to motor speed-constant HP (optional)

\*\*With Optional Compensation Board



FLEXIBILITY:

I. Motor:

1. Peak Current Limit
2. RMS Current Limit
3. Remote Current Limit
4. Optional Adjustable Output Current Taper proportional to motor speed (constant HP)
5. Adjustable tachometer gain.
6. Adjustable tachometer loop bandwidth.

II. Control:

- \*\*\* 1. High or Low Gain Selection
- \*\*\* 2. Single ended or differential input
- 3. Auxiliary signal input

III. System:

- \*\*\* 1. Remote Peak or RMS current limit (Dynamically adjustable - optional)
- \*\*\* 2. Jumper selectable Input logic operation of remote enable/disable
- \*\*\* 3. Jumper selectable Input logic operation of A limit switch
- \*\*\* 4. Jumper selectable Input logic operation of B limit switch
- \*\*\* 5. Jumper selectable Input logic operation of remote reset
- 6. Multiple axis configurations
- 7. Various interface boards allow choice of desired adjustments.
- 8. Wide bandwidth - Fast Response
- 9. Isolation eliminates need for isolation transformer
- 10. High switching frequency eliminates external output inductor with most P.M. DC motors
- 11. Variable bus voltage
- 12. Integral shunt regulator

\*\*\*JUMPER SELECTABLE

SPECIFICATIONS

<u>Westamp Model</u>	<u>A722X-17CFS (R)</u>
1. Peak Current (Available for 1-2 seconds)	± 30 Amperes DC
2. Peak Voltage	± 170 Volts DC
3. Continuous Current (0-50° C)	± 25 Amperes DC
4. Continuous Voltage	± 155 Volts DC
5. Continuous Power	3.8 75 KW : 5 HP
6. Input Voltage for Bus Supply	15-120 Volts AC, 3 phase
7. Input Voltage for Fan & Logic Power Supply	120 Volts AC, 2 amps
8. Switching Frequency	16 KHz
9. Gain	
Typical	0-8000 Amps/Volt
Differential Input	0-8000 Amps/Volt
Single Ended Input	0-8000 Amps/Volt
Tachometer Input	0-8000 Amps/Volt
10. Frequency Response (Current Loop)	2000 Hz
11. Signal Input Voltage (Typical)	± 10 Volts
12. Signal Input Impedance (Minimum)	20 K ohms
13. Tach Input Impedance	52 K ohms - 72 K ohms
14. Drift (Typical)	< 10 µV/Deg. C
15. Operating Temperature (Ambient)	0-50 Deg. C

NOTES

1. The amplifier can be used as a current source amplifier by placement of the gain select jumper on J2.
2. Frequency response is typical for the amplifier with NO velocity loop compensation. Velocity loop compensation networks for most practical applications will reduce the amplifier response.
3. Consult the factory for applications requiring continuous regeneration.
4. Maximum output voltage is derived from a 3 phase 120 VAC input source.
5. Single axis models use 120 VAC, single phase input. Multi axis models can accept 120 VAC, three phase input.
6. The output voltage of the amplifier depends upon the AC line voltage for the bus power supply. The DC bus voltage is approximately 1.4 the input AC voltage.
7. The output current monitor is capable of driving a zero center, 3 milliamperes ammeter. The calibration is 10 volts is equal to the peak rated current of the amplifier.
8. Fault conditions cause red LED's to illuminate, and the amplifier to "shut down".
9. The fault output signal at J1-9 can be used to remotely indicate any fault condition detected by the amplifier.
10. Low supply for logic/fan reduces the air flow from the blower. Do not operate the amplifier continuously, under this condition.

CHASSIS DIMENSIONS (INCHES)

MODEL	# OF AXES	L	W	H
A7221	1	11.5	5.5	8.9
A7222	2	10.5	9.25	8.9
A7224	4	10.5	13	8.9
A7226	6	10.5	17	8.9



## THEORY OF OPERATION

The A722 series (R) of amplifiers are current feedback, pulse width modulated servo amplifiers. Referring to the block diagram (see appendix A), the input to the amplifier may be connected differentially or single ended. The signal input is summed with a tachometer signal at the input to the velocity error amplifier loop.

The input signal and the tachometer signal are of opposite polarity and are almost equal in magnitude. The difference between the input signal and the tachometer signal is the velocity error signal which is amplified by the velocity error amplifier.

The output of the velocity error amplifier is connected to a peak current control potentiometer utilized to limit the current command signal. This network also provides a variable RMS current shutdown circuit for flexibility. The bandpass shaping network components close the voltage feedback loop around the velocity loop amplifier to stabilize the velocity loop.

The output of the velocity error amplifier is a current command signal which is summed with the current feedback signal at the current error summing junction. The current feedback signal is derived from the motor current sensing circuit and is directly proportional to the motor armature current. The difference between the current command signal and the current feedback signal is the current error signal. This current error signal is amplified by the current error amplifier. There is a bandpass shaping network around the current error amplifier for stabilizing the current loop.

The output of the current error amplifier is summed with a triangle wave generator at the input of two comparator/modulators. If the output is positive then one comparator outputs a pulse width modulated square wave at the frequency of the triangle wave generator. The same is true for the other comparator/modulator if the output is negative. Signals derived from external A and B limit, inhibit the modulators and have the effect of inhibiting the appropriate transistors thus, disabling one polarity of motor current. The output of each comparator/modulator drives the pre-drive logic stages. The polarity change sensor monitors the output of each pre-drive logic circuit and prevents turn on of the opposite transistor for a predetermined period of time after polarity change has been detected. This feature allows the storage time of the transistors to expire before the opposite transistor is allowed to turn on thus, preventing "shoot-through" conditions from existing.

The output transistor modules are connected in two totem pole configurations to provide bipolar output to a DC, brush type motor. There are current sensing resistors in series with each of the outputs to provide a signal proportional to the motor armature current. A current sensing resistor, in series with the bus, monitors bus current for over-current conditions. If such a condition exists then the amplifier pre-drive logic circuits are "disabled" and can only be reset by the reset input (J1-13) or by removal and reapplication of power.

## PROTECTIVE FEATURES

The A722 Amplifier provides many advanced safety features. These safety features help protect personnel, machinery, motors and the amplifiers. The amplifier will shut down and the appropriate red LED will be illuminated if:

1. Motor armature windings grounded - CR24
2. The output leads are shorted together - CR25
3. Bus power supply voltage exceeds the upper limit of the operating voltage - CR23
4. RMS current exceeds the amplifiers rating or setting - CR22
5. Ambient temperature exceeds the amplifier rating of 50°C - CR21
6. The sum of the two logic supplies is less than 22.5 volts (non-latching) - CR23
7. The A or B limit is activated (non-latching) - CR20
8. The remote disable is activated by the user (non-latching) CR20

Any of the above conditions can be removed by utilizing the reset option or by removal and re-application of power. In either case, the amplifier will become operative only if the condition which caused the amplifier to "shut down" has been removed. The non-latching limit and disable conditions must be enabled to resume operation.

## CONNECTORS

### Connector J1

- Pin 1 - Signal common with J4 jumper on pins 1 & 2 (inverted signal input with the jumper at J4 on pins 2 & 3)
- Pin 2 - Signal input (non-inverted signal common with J4 Jumper on pins 2 & 3)
- Pin 3 - Tachometer input
- Pin 4 - Signal common
- Pin 5 - Auxiliary signal input must be used (with optional compensation board)
- Pin 6 - A limit (positive signal clamp). (operation determined by J9)
- Pin 7 - B limit (negative signal clamp). (operation determined by J10)
- Pin 8 - Remote enable/disable input (operation determined by J11)
- Pin 9 - Fault detection output
- Pin 10 - +12.0 Volts
- Pin 11 - Signal common
- Pin 12 - -12.0 Volts
- Pin 13 - External reset of the latched shut-down conditions. (operation determined by J12)
- Pin 14 - Programmable Current Limit: The RMS current can be remotely, dynamically adjusted at J1-14 when the jumper of J6 is placed on pins 1 & 2. The peak current can be remotely and dynamically adjusted with the use of the programmable peak limit compensation board (optional).
- Pin 15 - Current Monitor ( $\pm 3$  A/V)

Connector J2

This 4 pin connector is provided with a 2 pin jumper. Connecting pins 1 and 2 with the jumper makes the gain of the velocity loop high. For more balance control, while in high gain, remove the jumper completely. Connecting pin 3 and 4 together with the jumper reduces the gain by a factor of 1000. The amplifier may be used as a current source by installing the jumper on pins 3 and 4. When the amplifier is in the current source mode and the signal gain potentiometer is set all the way CW, the gain is approximately 8 amperes/volt.

Connector J3 - 6 pin logic supply input connector

Pin 1 - -12 Volts  
Pin 2 - Common  
Pin 3 - +12 Volts  
Pin 4 - Phase loss signal input from power supply module (optional)  
Pin 5 - Common  
Pin 6 - +12 Volts

Connector J4

A 3 pin connector for selecting which input pin (J1-1 or J1-2) shall be grounded. For differential input, remove this jumper completely.

Connector J6

A 3 pin connector for selecting the operation of J1-14, programmable current limit input. J6 is supplied with pins 2 and 3 jumpered for standard operation. With pins 1 and 2 jumpered, the rms current is variable by reducing the input of J1-14 from a maximum of 10 volts. With the installation of the programmable peak limit compensation board. (optional), the peak current can be varied at J1-14. Increasing the input at J1-14 from 0-10V, with the J6 jumper on pins 2 & 3, would decrease the peak current output.

Connector J7

A 13 pin connector used to connect the compensation board to the main control board. Pin 11 is removed and is not used. Always install the compensation interface board with P7-1 mated to J7-1.

Connector J9

A 3 pin connector for selecting the operating logic of the "A" limit switch input J1-6. If the jumper is placed on pins 1 and 2 then a normally closed switch should be used. If the jumper is placed on pins 2 and 3 then a normally open switch should be used. J9 is supplied with Pins 2 and 3 jumpered for standard operation.

Connector J10

A 3 pin connector for selecting the operating logic of the "B" limit switch input J1-7. If the jumper is placed on pins 1 and 2 then a normally closed switch should be used. If the jumper is placed on pins 2 and 3 then a normally open switch should be used. J10 is supplied with Pins 2 and 3 jumpered for standard operation.

Connector J11

A 3 pin connector for selecting the operating logic of the enable input J1-8. If the jumper is placed on pins 1 and 2 then a normally closed switch should be used. When the N.C. switch opens, the drive is disabled. If the jumper is placed on pins 2 and 3 then a normally open switch should be used. Closing the N.O. switch to ground will disable the amplifier. J11 is supplied with pins 2 and 3 jumpered for standard operation.

Connector J12

A 3 pin connector for selecting the operating logic of the reset input J1-13. If the jumper is placed on pins 2 and 3 then a normally open switch should be used. Momentarily closing of the N.O. switch will reset the latched shut down condition. If the jumper is placed on pins 1 and 2 then a normally closed switch should be used. Momentarily opening of the N.C. switch will reset the latched shut down condition. J12 is supplied with pins 2 and 3 jumpered for standard operation.

Connector J13

Connectors used to connect the output transistor block to the P.C. Board.

Connector J17

- Pin 1 - Motor output of drive module
- Pin 2 - Motor output of drive module
- Pin 3 - Negative bus power input to drive module
- Pin 4 - Positive bus power input to drive module

## SHUNT REGULATOR

When a motor slows down or stops, a portion of the kinetic energy stored in the motor and load is returned to the power supply. This energy is referred to as regenerative energy. Overhauling loads also cause regenerative energy.

The amount of energy regenerated is determined by the system operating conditions (bus voltage, speed, deceleration time, load) and the motor design (voltage constant, resistance, inertia).

The regenerative energy pumps up the bus power supply capacitor since the rectifiers will not allow it to return to the input power line.

The power supply is designed to absorb the regenerative energy provided the resultant pump up does not cause the bus voltage to exceed the allowable level.

Westamp amplifiers are protected against excessive pump up, that could damage the amplifier, by circuitry that continuously monitors the bus voltage.

If the bus voltage exceeds the pre-set safe level, the circuitry detects the fault condition, shuts down the amplifier and illuminates the RED OVERVOLTAGE L.E.D. (CR23). This fault condition can be detected remotely at connector J1-9 of the CONTROL CARD.

The shunt regulator is used to maintain allowable bus levels during the regeneration cycle by dissipating the excessive bus energy as power into a resistive load. Shunt regulator circuitry and the dissipating resistor are provided as part of the A722 servo drive module.

If the required system performance and operating conditions cause the overvoltage protection circuit to shut down the amplifier, it may be necessary to use an externally mounted shunt regulator resistor.

An external, separately mounted resistive load must be connected at TB801 (see the installation drawing) on the servo drive module.

The circuitry monitors the bus capacitor voltage. If the bus voltage reaches the set point the shunt transistor applies the bus voltage across the resistive load. The resistor dissipates power until the bus returns to the allowable operating levels.

For proper sizing of the external shunt resistor, consult the factory.

**IMPROPER SIZING OF THE SHUNT REGULATOR LOAD RESISTOR CAN DAMAGE THE AMPLIFIER.**

CONSULT THE FACTORY

## INSTALLATION:

Each amplifier in the A722x series comes with an individual installation drawing, which shows the various connections for power input, signal input, tachometer input, fan and bias power input and motor output (see appendix A for installation drawings).

While this manual may show in a general way how to make connections to the amplifier, it is imperative that the specific instructions that apply to your amplifier be followed.

Always be certain to apply the correct input voltage and frequency. The input power transformer for all the amplifiers in the A722x series are separately mounted. It is possible to use one power transformer for several amplifier units if that transformer is sized properly. Westamp transformers have dual voltage primaries and it is imperative that you make certain that the jumpers are on the correct transformer terminals for the input AC power source. The motor output is available on separate terminals mounted on the Power Supply Module.

**CAUTION: DO NOT USE GROUNDED TEST EQUIPMENT ON THE OUTPUT.  
DO NOT CONNECT EITHER OF THE OUTPUTS TO GROUND.**

The signal input is usually applied directly to Pin 2 of J1 and the input signal return is usually applied to pin 1 of J1. The signal input to the amplifier may be connected either differentially or single ended. To connect the unit differentially, remove the shorting plug at J4. If the shorting plug is connected at J4, then the input to the amplifier is single ended and either J1 pin 1 or pin 2 is connected to the signal common.

The tachometer signal is applied to Pin 3 of J1 and the tachometer return is connected to Pin 4 of J1. The tachometer signal gain is fixed. If an adjustable tachometer input is required, an optional adjustable compensation board must be specified. Use shielded wires for signal and tachometer inputs to prevent stray pickup and noise from being introduced into the amplifier. The amplifier bandwidth will be anywhere from 4000 Hz (no compensation) to a much lower frequency, depending upon the setting of the TC (time constant) potentiometer and the components in the servo compensation network. Installation drawings should be used to wire the amplifier/motor combination.

In some cases an inductor is connected in series between the amplifier output and the motor. This inductor is required if the inductance of the motor is below 0.6mh.

The amplifiers in this series require 120 VAC, 2 amperes for the fan and logic power (terminals 1 & 2 of TB401). The logic supply will continue to operate with 120 VAC, +10% / -20%. However, the fan will slow down reducing the cooling and the amplifier should not be operated for extended periods of time with low line power.

The input power for the bus power supply may range from 15 VAC to 120 VAC (+ 10%).

**PLEASE CHECK ALL CONNECTIONS BEFORE POWER IS APPLIED.**

#### ADJUSTMENTS:

The A722x series of amplifiers have several different compensation boards available. The unit may be operated with any of these compensation boards or with compensation components mounted on the main control card. In all cases there are always certain customer adjustments on the control card. Refer to the "Simplified Board Layouts" in appendix A. These adjustments are as follows:

**SIG Signal Gain:** Potentiometer R75 adjusts the signal gain. Turning R75 in a CW direction increases the signal gain.

**BAL Balance:** Potentiometer R76 is the balance control. It may be necessary to adjust the balance for zero output when zero input is applied. This should be adjusted after the Tach and Signal gains have been set.

#### Adjustable Compensation Board:

The simplified board layout shows the various adjustments available on the Adjustable Compensation Board. These adjustments are as follows:

**TACH Tachometer Gain:** Potentiometer R12 adjusts the tachometer loop gain. Turning R12 in a CW direction increases the tach loop gain.

**TC Time Constant:** Potentiometer R15 is the Time Constant Potentiometer. The TC potentiometer is used to stabilize the closed loop system. Turning R15 CW increases the Velocity Loop Bandwidth.

**CLM Peak Current Limit:** Potentiometer R28 adjusts the peak current output of the amplifier. With the potentiometer at the maximum CW position, the amplifier outputs its maximum peak rated current. The peak output current is decreased by turning potentiometer R28 in a CCW direction.

*NOTE 1:* R29 and R31 are factory adjustments and must not be altered.

#### Adjustable Compensation Taper Current Board:

This Compensation Board is designed for applications that require tapered current limit in addition to adjustable compensation. The tapered current limit values must be computed by the Westamp Factory and are generally factory set.

**DO NOT ATTEMPT TO SET THESE POTENTIOMETERS WITHOUT WESTAMP'S COMPUTED VALUES.**

Refer to the appendix for the location of the various adjustments on the Adjustable Taper Current Board. The TACH, TC and CLM adjustment procedure is the same as the Adjustable Compensation Board.

*NOTE 2:* On all Westamp servo amplifiers, turning potentiometers in a CW (clockwise) direction increases the parameter that is being adjusted. Turning potentiometers in CCW direction decreases the parameter being adjusted.

ADJUSTMENT PROCEDURES:

It is possible to compensate a servo system empirically without any theoretical evaluation of the system, provided that the system specifications are not stringent. For most applications, the procedure outlined in the Short Form "Set-Up Procedure" will result in adequate servo performance. The A722x series of servo amplifiers was designed to operate in very high performance servo systems. In order to achieve optimum servo performance, matching amplifier-motor-tachometer combinations are recommended. However, the A722x series amplifiers will provide good performance with many DC motor-tachometer combinations, by merely adjusting the TC and TACH gain potentiometers.

SHORT FORM SET-UP PROCEDURE  
(All PWM Amplifiers)

1. Check input voltages and determine proper transformer connections.
2. Measure the voltages before applying power to the amplifier chassis.
3. Connect in accordance with the proper installation drawing.  
NOTE: All multi-turn pots are 20 turns nominal.
4. Before applying power, adjust all potentiometers as follows:
  - a. Current limit pot (CLM) - fully CCW
  - b. "TC" pot - mid range (10 turns from either end)
  - c. "TACH" pot - turn fully CCW then turn CW 5 turns
  - d. "SIG" pot - mid range (10 turns from either end)
5. Apply power but DO NOT apply an input signal.
6. To check for proper phasing of the tachometer and motor: turn the "CLM" pot CW very slowly. If the motor starts to run away, shut off the power and reverse the leads of either the motor or tachometer.
7. Turn the power back on and repeat item 6. The motor should not rotate or may rotate very slowly (do not adjust the BAL pot at this time). Turn CLM pot to desired current. CLM pot setting allows the amplifier to deliver peak current as shown in the following  
Example:

20 Turn Pot
3 turns CW = 30 % peak current
6 turns CW = 60 % peak current
10 turns CW = 85 % peak current
14 turns CW = 95 % peak current
8. If the motor shaft rotates slowly with no signal applied, adjust the balance (BAL) pot until the motor stops.
9. With zero input signal, turn "TC" pot CW until the motor shaft starts to oscillate at high frequency. Turn CCW until the oscillation stops. Turn an additional  $\frac{1}{2}$  turn in a CCW direction.  
IMPORTANT - IF TC IS FULLY CCW AND THE SYSTEM IS STILL OSCILLATING AT HIGH FREQUENCY, SEE THE NOTES AT THE END OF THE DETAILED SET UP PROCEDURE.
10. Apply a small signal and observe motor shaft.



11. Increase or decrease tach gain pot for desired results.
  - a. Increasing TACH (turning pot CW) provides quicker settling time (higher bandwidth).
  - b. Decreasing TACH (turning pot CCW) provides slower settling time (lower bandwidth).
12. When the tachometer response is proper, do not change the TACH pot further.
13. If the motor drifts after the SIG and TACH pots have been set, it may be necessary to re-adjust the BAL pot.
14. Run the motor at a higher speed. If it runs smoothly, the system is adjusted properly. A rough sound indicates either the TC or the TACH is too far CW.
15. Set the required speed of the system by adjusting the SIG potentiometer. Turning the pot CW will increase the motor speed.
16. This completes the short form set-up. It is recommended that the adjustments be recorded on the form at the back of this manual.

#### DETAILED SET-UP PROCEDURE

If your system requires a more accurate TACH adjustment, the following procedure should be followed:

1. Perform Steps 1-10 on the previous pages.
2. Apply a small signal until the motor rotates. Observe the tachometer signal on an oscilloscope. *NOTE: Refer to Helpful Hints in appendix A.*
3. If the tach loop is overdamped, turn the TACH pot CW until one overshoot appears. The system is now set up for maximum bandwidth in the tachometer loop.
4. If overshoot in the tachometer loop is objectionable, then adjust the TACH pot CCW until the overshoot is eliminated.

*NOTE: One overshoot in the tachometer loop does not necessarily mean the position loop will overshoot.*

5. IF THE SYSTEM IS NOT PERFORMING PROPERLY AND IS MECHANICALLY SOUND, SEE NOTES AT THE END OF THIS SECTION..
6. If motor shaft rotates slowly with no signal input, it may be necessary to re-adjust the BAL pot until the motor stops.
7. Recalibrate the SIG signal gain pot to obtain the proper output speed.
8. All other adjustments are factory set and should not be altered.

**CAUTION!** POWER MUST BE OFF WHEN REMOVING MODULES OR CHANGING COMPONENTS

NOTES:

1. Check system for backlash, wind-up, lost motion, bad coupling or other mechanical problems.  
AFTER PERFORMING ANY OF THE FOLLOWING CHANGES, REPEAT THE SET-UP PROCEDURE - START WITH STEP 4 OF the short form procedure.
2. If the system exhibits a high frequency oscillation even though the TC pot is fully CCW (this may be due to motor resonance) increase C7. It may be necessary to increase C3 = 2 mfd. & C5 = .22 mfd
3. If the system requires more DC gain:
  - a. Increase C6 to approximately .1 mfd and decrease R11 to approximately 2K $\Omega$ . You might have to increase C7 as shown in note 2.
  - b. Reduce value of R26. Caution! The balance adjustment will become more sensitive.
4. If the system has high inertia, or a high inertia motor is being used, it may be necessary to change C6 and R11. Reference 3a above.

SET-UP PROCEDURE USING RESISTIVE MEASUREMENTS

This setup procedure is used only after the desired settings for the SIG, TACH, TC and CLM potentiometers have been established. Use either the Short Form or Detailed set-up procedure to determine these settings. DO NOT USE GROUNDED TEST EQUIPMENT.

1. Remove all power. Measure and record the resistance values as indicated in the following steps. The ohm meter common should be connected to the wire hoop common on the upper left hand corner of the main control board.
2. SIG Potentiometer: Measure and record the resistance from TP2 to the wire hoop common  
\_\_\_\_\_
3. TACH Potentiometer: Measure and record the resistance from TP1 on the interface board to common.  
\_\_\_\_\_
4. TC Potentiometer: Measure and record the resistance from TP2 on the interface board to common.  
\_\_\_\_\_
5. CLM Potentiometer: Measure and record the resistance from TP3 on the interface board to TP1 of the Main Control board. \_\_\_\_\_
6. To adjust a new board, set the potentiometers to the values determined in steps 2 through 5. *Note!* The TC and CLM adjustments interact and must be adjusted several times to achieve the desired results.
7. Remove the ohm meter and turn CLM fully CCW. Apply power and slowly turn CLM clockwise. If the motor starts to run away, turn off power and reverse either the motor or the tach leads. Turn power back on to verify that the motor does not run away.
8. Turn power off and re-adjust the CLM potentiometer as in step 5. Remove the ohm meter and apply power. If the motor shaft rotates slowly with no signal applied, adjust the BAL potentiometer until the motor stops. Remove power and repeat step 6 to insure TC and CLM are set at the proper values.

### RMS CURRENT ADJUSTMENTS:

For many applications, the rated RMS current of the amplifier is greater than the continuous current rating of the motor it is driving. If motor protection, external to the amplifier, is not provided, it is recommended that the RMS current limit be adjusted to equal the motor rating. Adjust R51 on the main control board.

*NOTE: R51 is a single turn potentiometer. Turning R51 CCH reduces the RMS current limit, linearly to zero. (i.e... Mid range on R84 will allow 50 % of rated RMS current; 12.5A).*

### REMOTE ADJUSTMENT:

J1-14 can be used to remotely adjust the RMS current capability of the amplifier. To use J1-14 as the remote RMS current input you must place the jumpers of connector J6 on pins 1 and 2. Decreasing the voltage input at J1-14, from a maximum of 10 volts, decreases the RMS current of the amplifier.

### TROUBLE SHOOTING:

Refer to the appropriate installation drawing, board layout drawings and schematic contained in appendix A.

1. Examine the unit visually for loose connections, broken wires or damaged components. Verify that Pins 6, 7, 8, and 13 are not being activated by external equipment.

2. If a fault indicator red light is on, read over the Protective Features and Other Features Sections. Determine the reason for the trip indication. Do not merely reset the amplifier; permanent damage could result:

- a. +12 VDC logic supply is low
- b. High bus voltage
- c. Output transistors
- d. Faulty motor
- e. Over Temperature

Steps 3 through 6 are a systematic check of each of the above conditions.

3. A low or faulty logic supply may be a result of:
- a. Low 120 VAC supply
  - b. Blown logic supply/fan fuse - F401
  - c. Defective logic supply
  - d. Excessive load

Check the logic supply fuse (F401) and measure the 120 VAC input. If the input voltage and fuse are proper and the output voltage is low, measure the load current on each of the outputs (Check the model number of your specific logic supply):

Return the logic supply to the factory for repair if the load currents within specification and the outputs are low. If load currents are excessive, determine the cause by systematically disconnecting the external load and each of the output modules while monitoring load current. Each output module assembly draws approximately .350 amperes max. from +12 V and .300 amperes max. from -12 V.

4. Problems with the bus voltage can be attributed to one of the following:
  - a. Transformer wiring incorrect
  - b. Defective transformer
  - c. Defective rectifier bridge
  - d. Defective shunt regulator

Verify that the transformer is wired properly. Measure the bus voltage and the input bus power voltage including the isolation transformer primary (to verify the transformer). On three phase input power, make sure to measure all three line to line voltages. If one phase is missing or low, it can reduce the bus voltage considerably, under load. Loss of any input phase will cause the A722 amplifier to become disabled. For three phase power, the bus voltage will normally vary from 120 % to 140 %. Bus voltages significantly different indicate a problem with the bus rectifier, provided the input bus power is proper.

The amplifier may experience an overvoltage trip if the shunt regulator is not functioning properly or the shunt resistor is inadequate. The trip will occur during a period when the motor is decelerating. If fault trips are experienced during decel periods, monitor the bus voltage with an oscilloscope. Voltage on the bus will build up during decel periods if the shunt resistor is not sized properly or the shunt regulator is not functioning properly.

5. Defective output transistors will cause a fault trip immediately upon application of power. Disconnect the motor from the amplifier and re-apply power. If the fault indication still exists, return the output module to the factory for repair.

6. Motor failures will cause a fault trip even though the system may appear to operate properly in all other respects. Shorted, grounded or open armature windings will cause a fault trip either at power turn on or while the motor is running. Brush dust buildup on the brush rigging will appear as a grounded armature. Inspect the motor for burn spots in the winding or evidence of arcing. Commutation problems will leave a brown residue on the brushes and the face of the brush will be dull and rough rather than smooth and shiny. Commutation problems can be caused by faulty armature windings or improper application of the motor.

#### MULTI AXIS SYSTEMS:

Troubleshooting a multi axis system can create some unique situations since bus voltage or a low logic voltage may cause one or more modules to indicate a fault trip. When one or more modules trip or random modules trip, check the logic supply and shunt regulator as outlined in steps 3 and 4. If the logic supply and shunt regulator check good, it is possible that the shunt regulator may be sized improperly, and require an "external" shunt regulator resistor.

The external shunt resistor should be connected to the drive module at TB B01. Remove fuse F801 when using an external shunt resistor.

Consult the factory for proper sizing of the shunt resistor. Improper sizing will damage the drive module.

TYPICAL INSTALLATION AND FIELD PROBLEMS:

<u>SYMPTOM</u>	<u>CAUSE</u>
High Bus Voltage	Defective Shunt Regulator Wrong Transformer Tap Shunt Resistor Sized Incorrectly High Line Voltage.
Excessive Surge Currents	Either Motor Line Grounded Output Leads Shorted Defective Output Transistor
Excessive Current At High Motor Speeds	Exceeded Safe Commutation Zone of Motor Misadjustment of Current Taper Defective Motor.
Excessive RMS Current	Excessive Duty Cycle Defective Motor Shorted Motor Lines - Intermittent Improper Compensation
Over Temperature	Fan Obstructed, Defective or Operating from Low Voltage Ambient Temperature too High
Low Logic Supply Voltage	Overload on Logic Supply Defective Logic Supply
Low Bus Voltage	Power Line Sag. Defective Line Rectifiers

**NOTE:**

All of the above conditions will result in a fault trip with indication with the exception of low bus voltage. Low bus voltage may not give a fault trip indication but will result in poor acceleration performance and the motor may not reach the desired top speed. Should the bus voltage fall below 10 VDC the amplifier will become disabled. Increasing the bus voltage above 10 VDC will re-enable the amplifier.

**TO RE-SET DRIVE:**

Momentarily activate the reset line at J1 pin 13 or remove the logic power, wait approximately 15 seconds, then re-apply power. The drive will restart if the fault condition has cleared.

Customer \_\_\_\_\_

Amplifier Model \_\_\_\_\_

Machine \_\_\_\_\_

AMPLIFIER SETTINGS

AXIS	#1	#2	#3	#4
Module P/N if Known				
Potentiometer Settings from Fully CCW position				
Aux Pot				
Signal Pot				
Differential Input Yes/No				
Tach Pot				
Tc Pot				
Current Limit Pot				

*SPECIAL NOTES:* Here you might want to indicate the overall # of turns of the pots.  
 See Application Note section on pots.

*You might want to copy this page and put it with the machine.* Date:

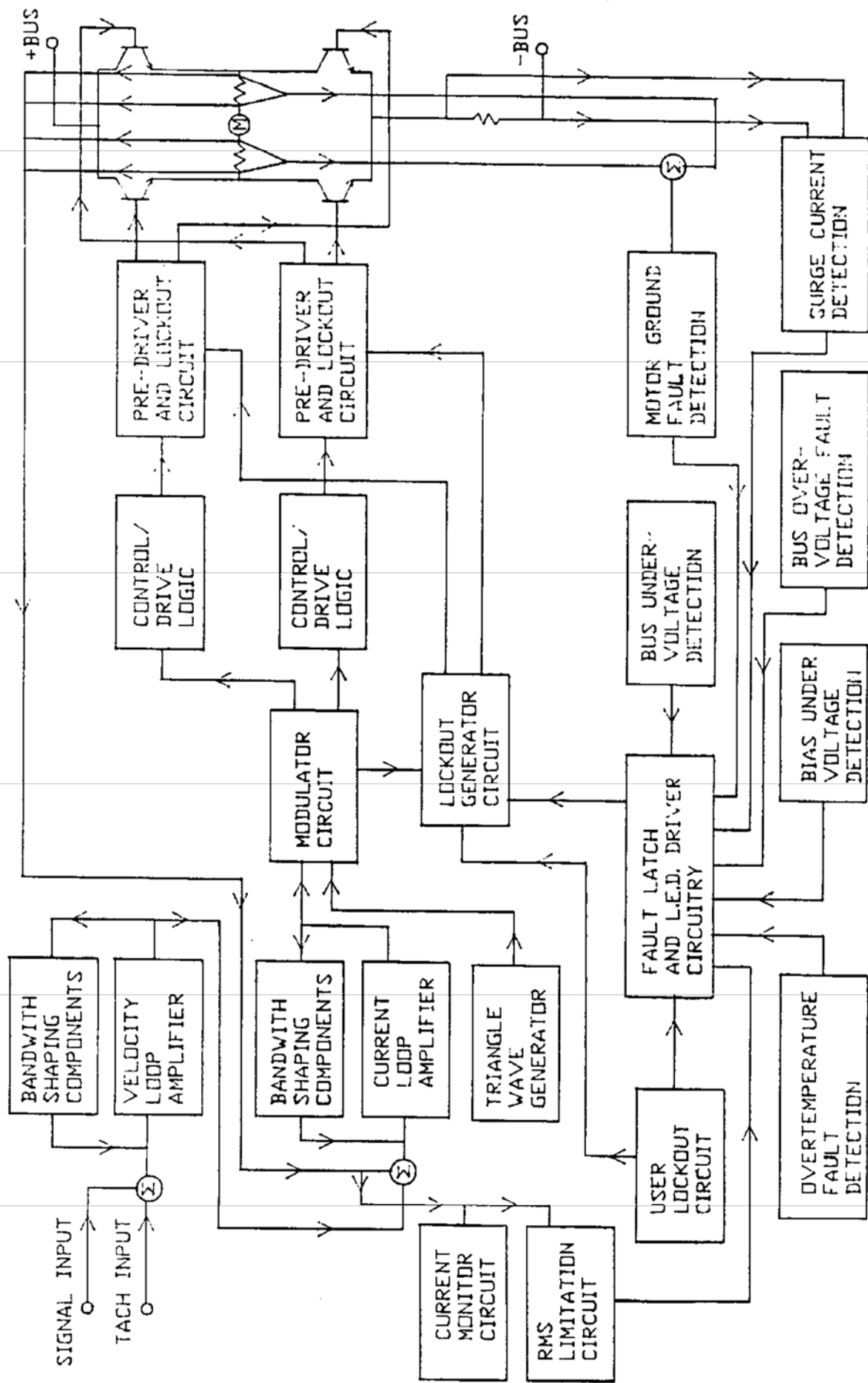

BLOCK DIAGRAM

REV	DESCRIPTION	BY	DATE
A	INITIAL MANUFACTURE	MM	1/16/64
B	PER ED 037019	MM	1/16/64
C	PER ED 097008	MM	1/16/64
D	PER ED 0168007	MM	1/16/64

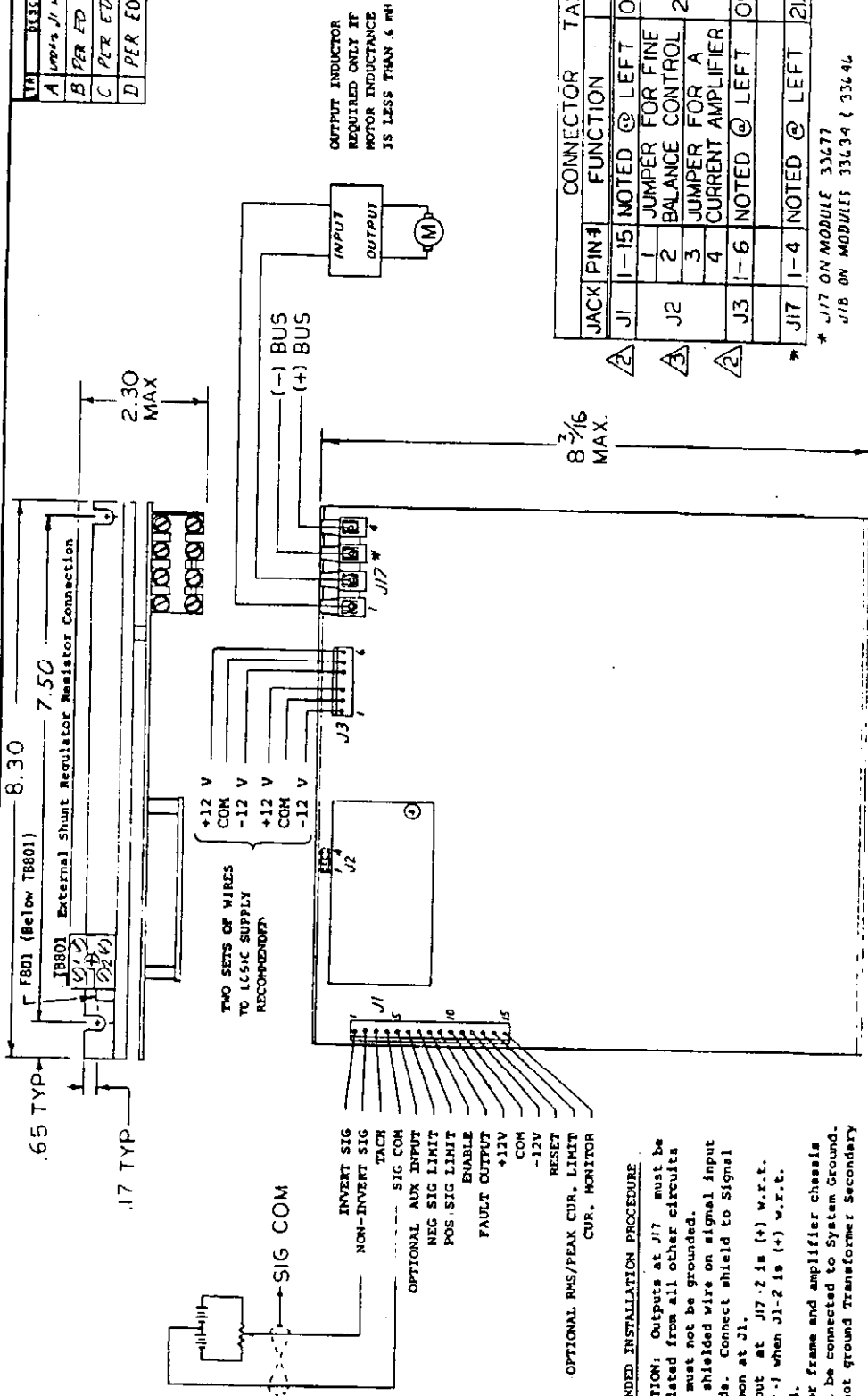

JACK PIN#	FUNCTION	MATING P/N
J1	1-15 NOTED @ LEFT	09-50-7151(MOLEX)
J2	1	JUMPER FOR FINE BALANCE CONTROL
	2	JUMPER FOR A CURRENT AMPLIFIER
	3	JUMPER FOR A CURRENT AMPLIFIER
	4	JUMPER FOR A CURRENT AMPLIFIER
J3	1-6 NOTED @ LEFT	09-50-7061(MOLEX)
J17	1-4 NOTED @ LEFT	21-310-0453(ELECTROVERT)

\* J17 ON MODULE 33677  
 J18 ON MODULES 33634 & 33646

**RECOMMENDED INSTALLATION PROCEDURE**

- CAUTION: Outputs at J17 must be isolated from all other circuits and must not be grounded.
- Use shielded wire on signal input leads. Connect shield to Signal Common at J1.
- Output at J17-2 is (+) w.r.t. J1-4.  
 J17-1 when J1-2 is (+) w.r.t. J1-4.
- Motor frame and amplifier chassis must be connected to System Ground. Do not ground Transformer Secondary

PART NO.	DESCRIPTION	MATERIAL	SIZE
UNLESS OTHERWISE SPECIFIED, ALL DIMENSIONS ARE IN INCHES-FRACTIONS & DECIMALS. DIMENSIONS ARE TO CENTER UNLESS OTHERWISE SPECIFIED.	INSTALLATION DRAWING		
WESTAMP INCORPORATED 1842 18TH STREET SANTA MONICA, CAL.			
FIGURE	SCALE	DATE	REV
	A722x	01/16/64	D
		33600	
		SHEET 1	

4. F801 IS A MDA 3 2/10 AMP FUSE  
 MOLEX TERMINALS (P/N:08-50-0114) ARE REQUIRED FOR CONNECTOR.  
 MOLEX TERMINALS (P/N:08-50-0106) ARE REQUIRED FOR CONNECTOR.  
 1. MIN. PITCH BETWEEN MODULES ON ASSY IS : 2.00"  
 NOTES:UNLESS OTHERWISE SPECIFIED



REV	DESCRIPTION	BY	DATE
A	REQUIRED J1 ADJUSTMENT	AM	7/11/87
B	REQUIRED REFERENCING	AM	7/11/87
C	PER ED 09700B	DA	1/14/88
D	PER ED 11802Z	MM	1/15/88

FUSE DATA			
Model No.	F401	F801	
Fuse Type	MDA	MDA	
A7221...	3 Amp	3 2/10 A	

**RECOMMENDATION INSTALLATION PROCEDURE**

1. CAUTION: Outputs at TB402 must be isolated from all other circuits and must not be grounded.
2. Use shielded wire on signal input leads, connect shield to Signal Common at J1.
3. Output at TB402-6 is (+) w.r.t. TB402-5 when J1-2 is (+) w.r.t. J1-4.
4. Motor frame and amplifier chassis must be connected to System Ground. Do not ground Transformer secondary.

NOTE: AMPLIFIER HEIGHT IS 8.88"

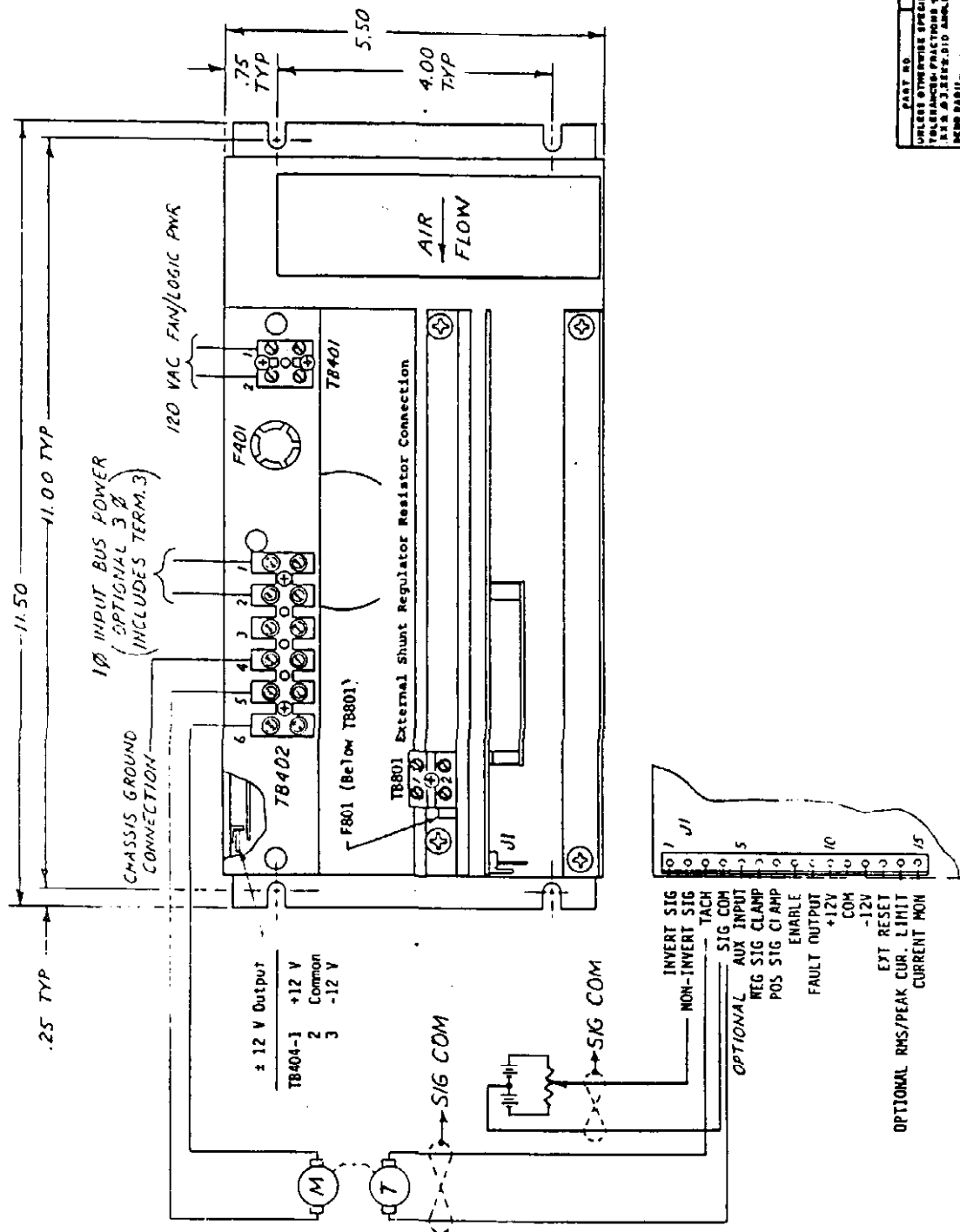

PART NO.	DESCRIPTION	MATERIAL	ITEMS
	INSTALLATION DRAWING		
	A7221		
DATE	2-7-87	SCALE	AS SHOWN
REV	1	QTY	33600
		SHEET	2

UNLESS OTHERWISE SPECIFIED, TOLERANCES FRACTIONS & DECIMALS ARE AS SHOWN UNLESS OTHERWISE SPECIFIED. BREAK DIMENSIONS 1000-1000. © 1987

NOTE: AMPLIFIER HEIGHT IS 8.88"

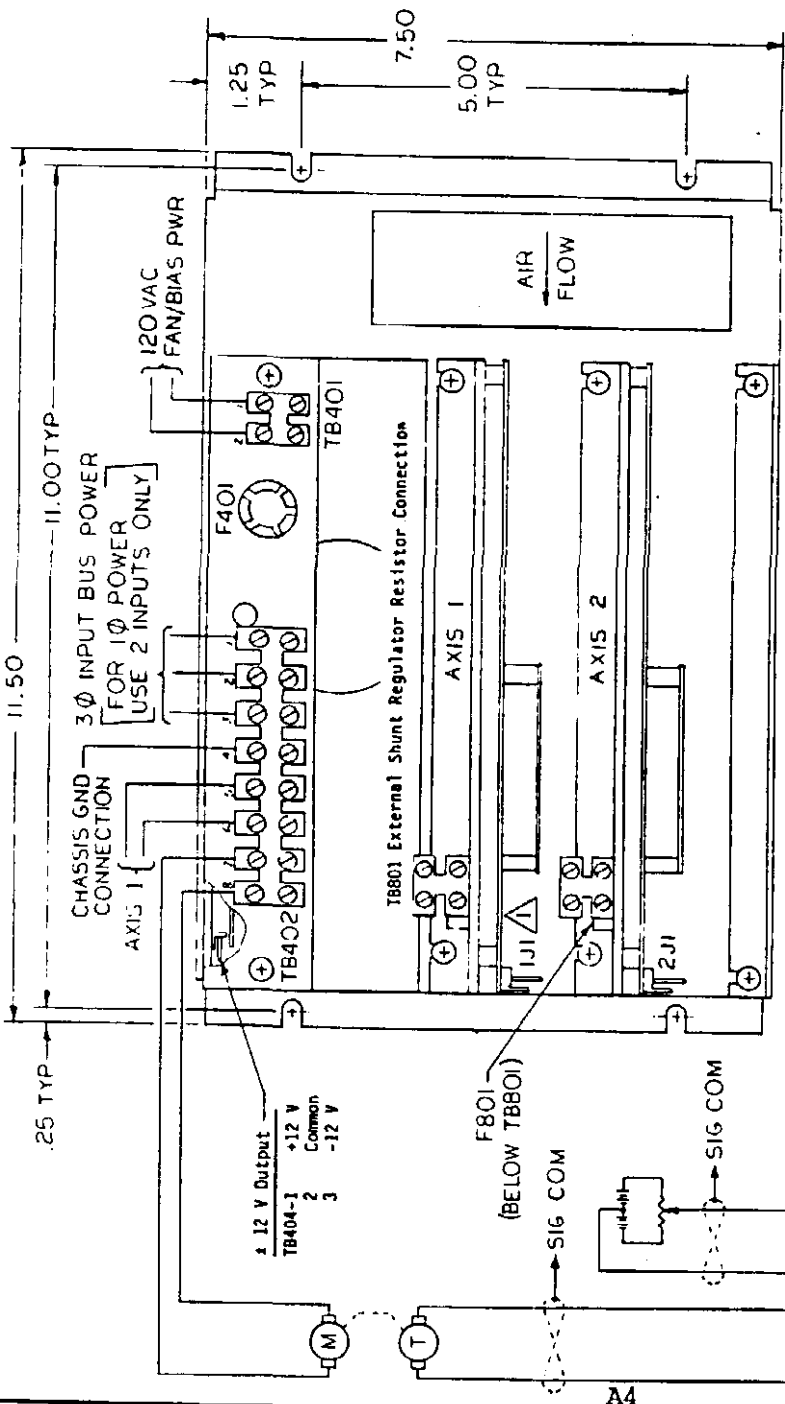

Fuse Data			
Model No.	Fuse Type	F401	F801
		AGC	MDA
		2Amp	3 2/10 A

- RECOMMENDATION: INSTALLATION PROCEDURE**
- CAUTION: Outputs at TB402 must be isolated from all other circuits and must not be grounded. Use shielded wire on signal input leads, connect shield to Signal Common at J1
  - Output at TB402-8 is (+) w.r.t. TB402-7 when 2J1-2 is (+) w.r.t. 2J1-4. Motor frame and amplifier chassis must be connected to System Ground. Do not ground Transformer secondary.

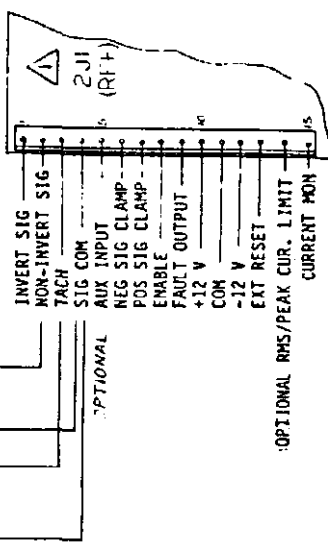

INSTALLATION OF AXIS 2 IS TYP FOR AXIS 1 RESPECTIVELY  
 NOTES: UNLESS OTHERWISE SPECIFIED

DATE	DESCRIPTION	MATERIAL	USER
INSTALLATION DRAWING		WESTAMP	
MODEL A7222		INCORPORATED	
DATE 2-10-67		1042 18TH STREET	
SCALE		SANTA MONICA, CAL.	
REV.	33600		
3			

REV	DESCRIPTION	BY	DATE
A	ADDED TB 404	DA	11/14/71
B	PER EO 09700B	DA	7/14/71
C	PER EO 07801A	nm	7/27/71

FUSE DATA	
Fuse	F401 F801
Type	AGC MDA
Model No.	A7223-17
Rating	2 Amp 3 2/10 A

- RECOMMENDATION INSTALLATION PROCEDURE**
- CAUTION: Outputs at TB403 must be isolated from all other circuits and must not be grounded. Use shielded wire on signal input leads, connect shield to signal common at J1.
  - Output at TB403-8 is (+) w.r.t. TB403-7 when 4J1-2 is (+) 4J1-4. Motor frame and amplifier chassis must be connected to System Ground. Do not ground Transformer secondary.

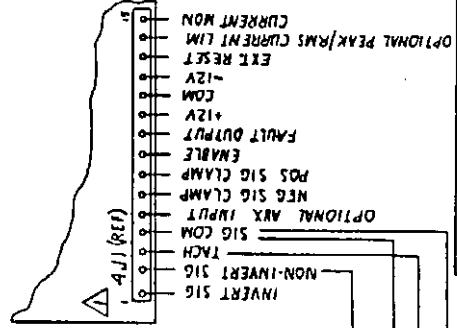
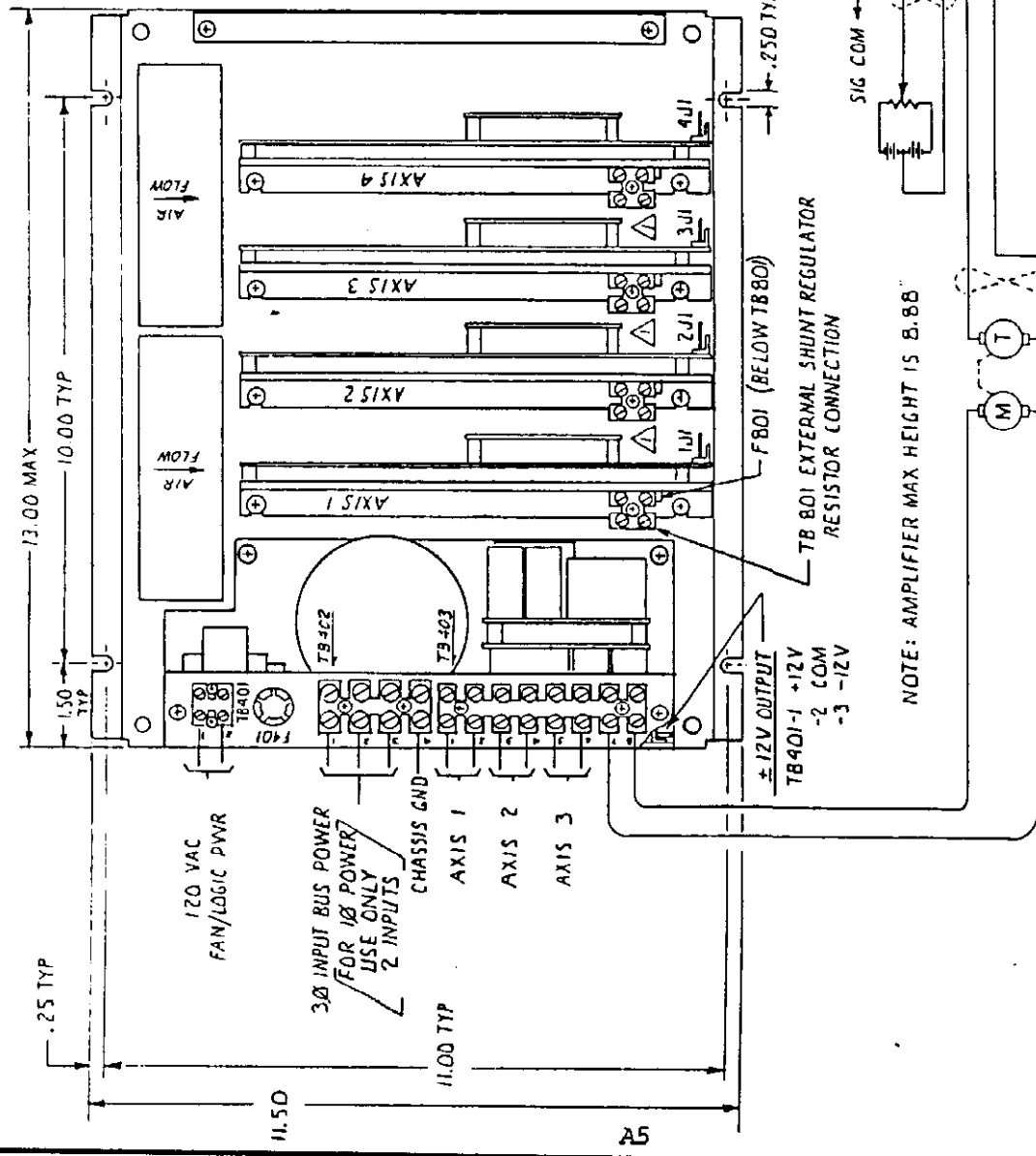

WESTAMB	
INCORPORATED	
1542 15TH STREET	
SANTA MONICA, CA	
DATE	33600
REV	3
DATE	2-13-97
REV	1
DATE	11/14/71
REV	1
DATE	7/14/71
REV	1
DATE	7/27/71
REV	1
DATE	7/27/71

NOTE: AMPLIFIER MAX HEIGHT IS 8.88

INSTALLATION OF AXIS 4 IS TYP FOR ALL AXIS RESPECTIVELY.

NOTES: UNLESS OTHERWISE SPECIFIED

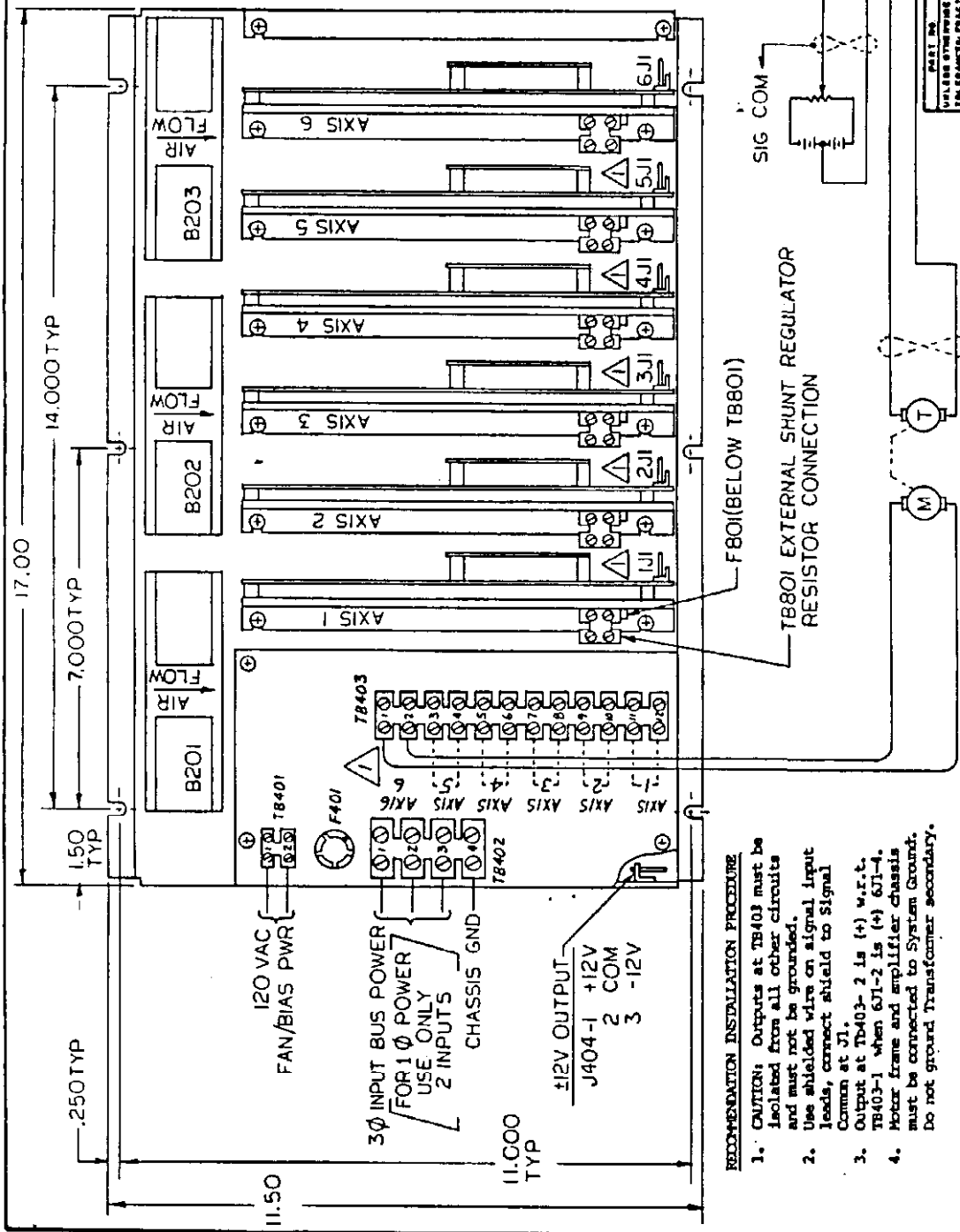

FUSE DATA			
Model No.	F401	FBOI	
Type	MC	MD	
	2 Amp 3 27/10 A		

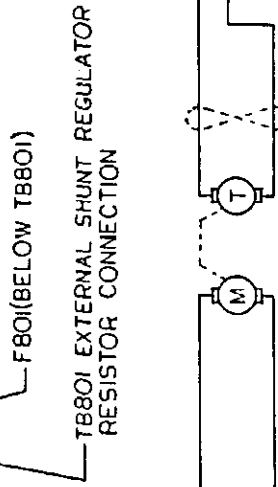
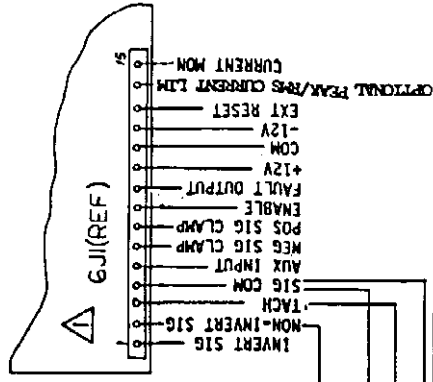

- RECOMMENDATION INSTALLATION PROCEDURE**
- CAUTION: Outputs at TB403 must be isolated from all other circuits and must not be grounded.
  - Use shielded wire on signal input leads, connect shield to Signal Common at J1.
  - Output at TB403-2 is (+) w.r.t. TB403-1 when 6JI-2 is (+) 6JI-4.
  - Motor frame and amplifier chassis must be connected to System Ground. Do not ground Transformer secondary.

2. AMPLIFIER MAX. HEIGHT IS 8.88  
 △ INSTALLATION OF AXIS 6 IS TYP FOR ALL AXIS RESPECTIVELY  
 NOTES: UNLESS OTHERWISE SPECIFIED

**WESTAMP**  
 INCORPORATED  
 1542 18TH STREET  
 SANTA MONICA, CAL

**INSTALLATION DRAWING**  
 A7226  
 DATE: 5-12-87  
 SCALE: 1/8" = 1"

WES-33600  
 SHEET 7

HELPFUL HINTS:

1. Tachometer should be observed on an oscilloscope where sweep speed is set at .1 seconds/centimeter and adjust the vertical attenuator to provide a convenient displacement in response to the signal input.
2. Small step input commands may be provided with a DC simulator ( battery box ) while observing the tach response on the oscilloscope.
3. Typical pictures you will see on oscilloscope of tach profiles.

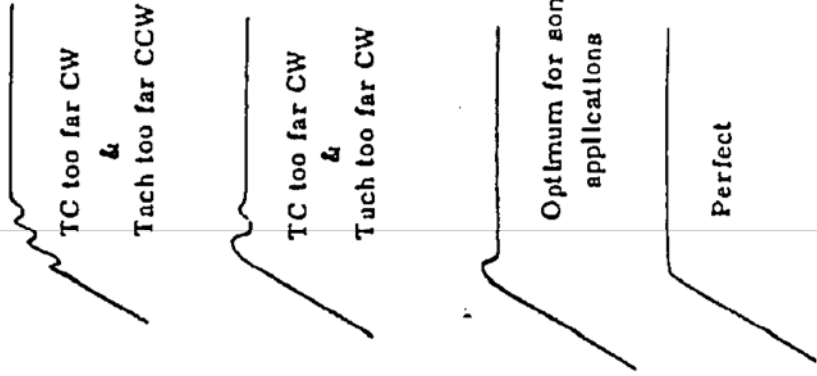
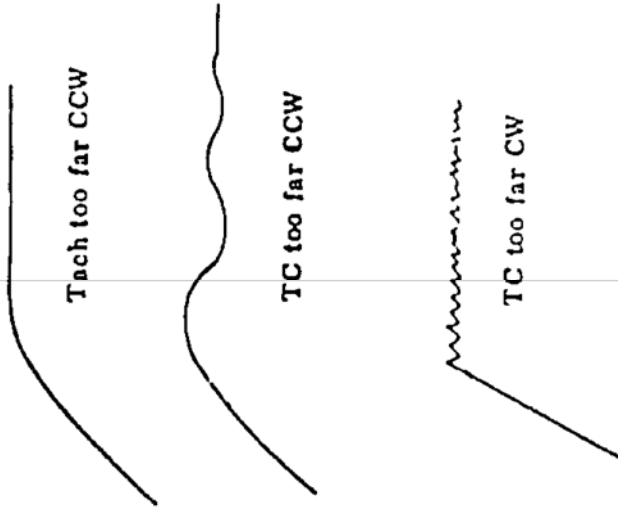

Tach Pictures



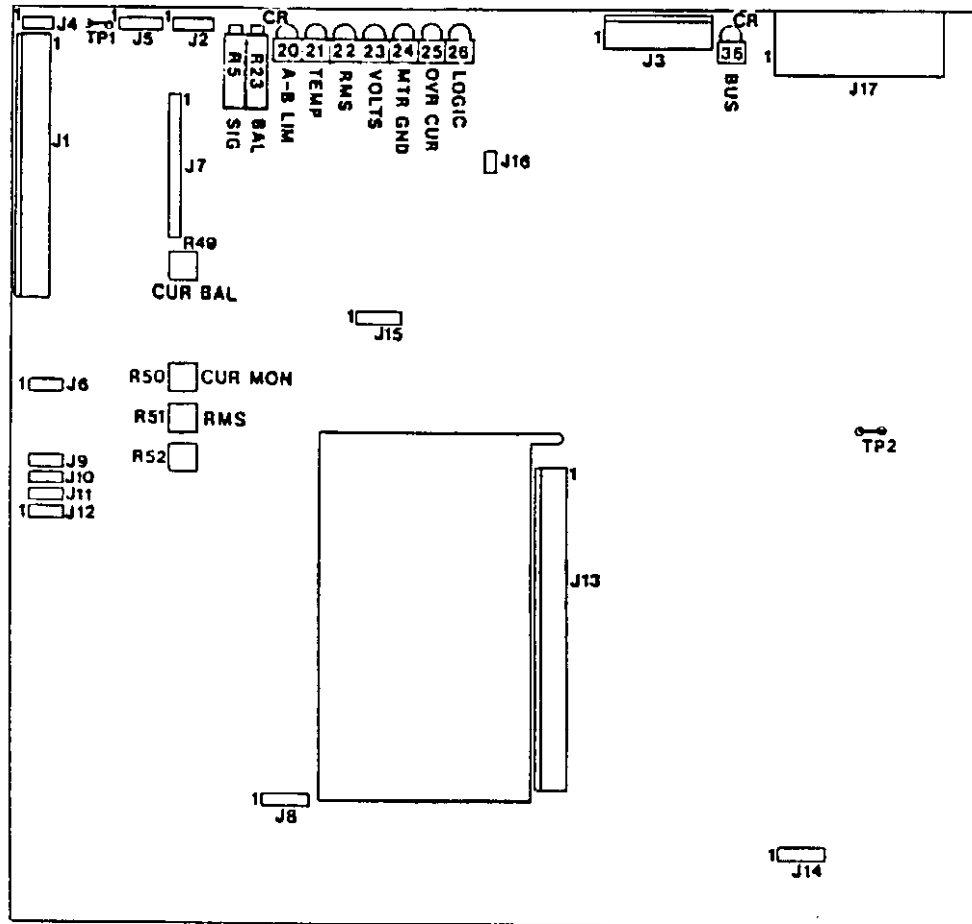
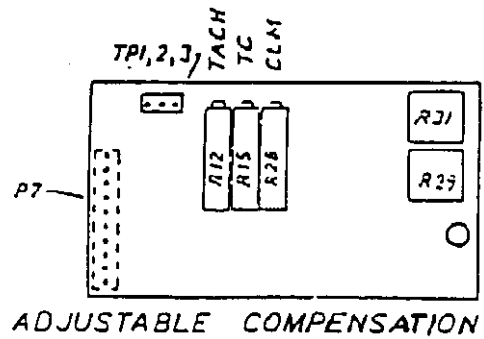

A722  
SIMPLIFIED CONTROL BOARD LAYOUT

1. FILED COPY  
 2. FILED ORIGINAL  
 3. FILED PHOTO  
 4. FILED DRAWING  
 5. FILED SPECIFICATION  
 6. FILED PARTS LIST  
 7. FILED INSTRUCTIONS  
 8. FILED TEST PROCEDURES  
 9. FILED WIRING DIAGRAMS  
 10. FILED OTHER DOCUMENTS

106 ELECTRICAL PARTS LIST JAN 1967  
 106 ELECTRICAL PARTS LIST JAN 1967  
 106 ELECTRICAL PARTS LIST JAN 1967  
 CONTROL DRIVE BOARD ASSY  
 WESTAMP  
 A772  
 3675 D

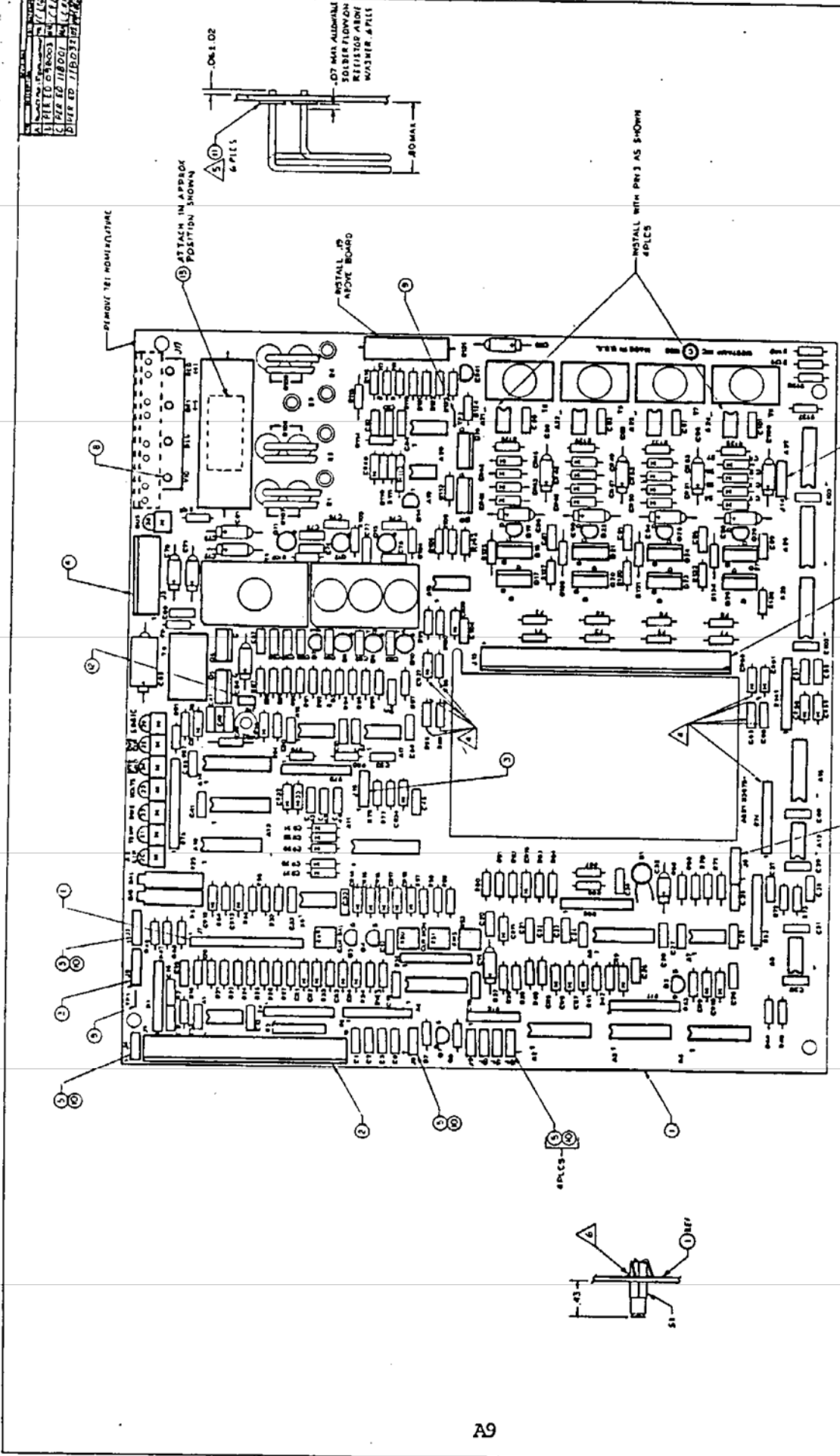

1. ASSEMBLE BOARD WITH EPSON ON EITHER SIDE OF BOARD.  
 2. SOLDER ITEMS TO BOARD WITH HI-TEMP SOLDER. REF: METERING-PHAR-DE ALERT 2-10 (80-1-374)  
 3. CLIP LEADS CLOSE TO BOARD ON BACK SIDE. REF: METERING-PHAR-DE ALERT 2-10 (80-1-374)  
 4. ALL TRANSISTORS TO BE AS CLOSE TO BOARD AS POSSIBLE TO MINIMIZE LEAKAGE.  
 5. INSTALL ALL CAPACITORS FLUSH TO BOARD.  
 6. REMOVE PINS 3 & 5 FROM 4, 17, 20, 22, 23, 24, 25.  
 7. REMOVE PINS 3 & 5 FROM 4, 17, 20, 22, 23, 24, 25.

REVISED	BY	DATE
A	ALPRED R284	JAN 5 4 54

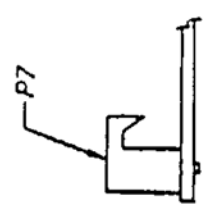
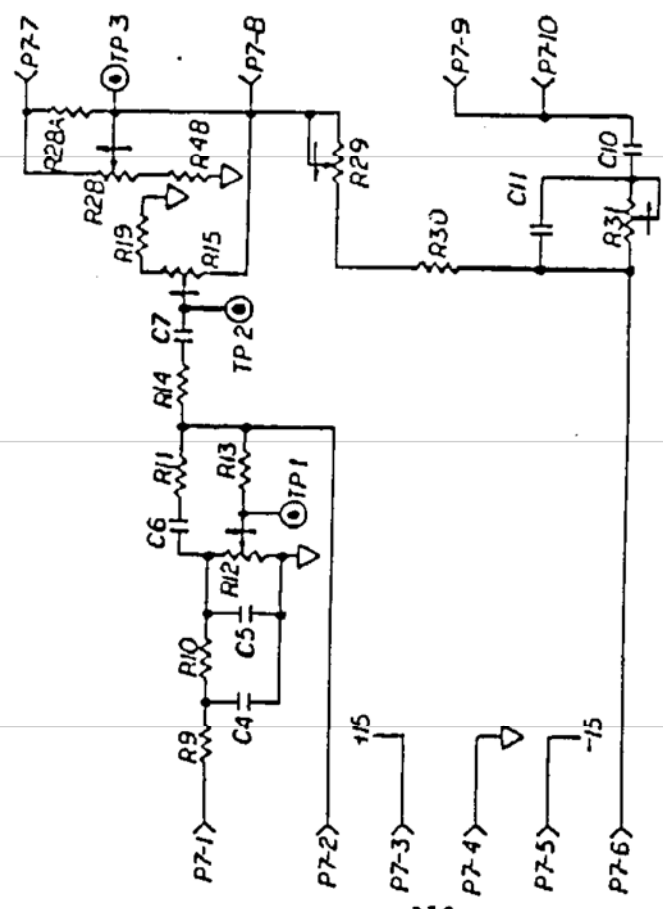

TP1-3

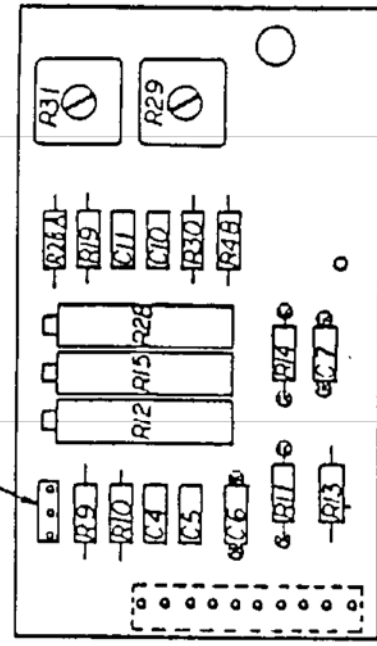

FOR ELECTRICAL PARTS LIST SEE EPL 33030		DATE
ADJUSTABLE COMPENSATION BOARD		DATE
WESTAMB		DATE
1848 18TH STREET		DATE
SANTA MONICA, CAL.		DATE
A7217		DATE
33030		DATE
A		DATE

A10



ALL INFORMATION CONTAINED HEREIN IS UNCLASSIFIED

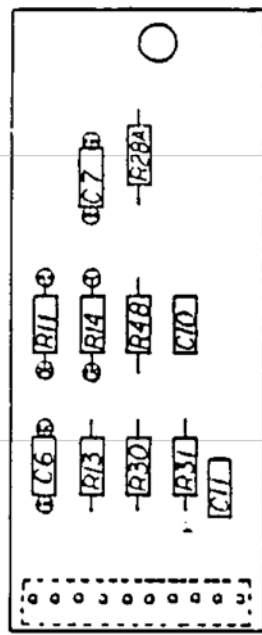
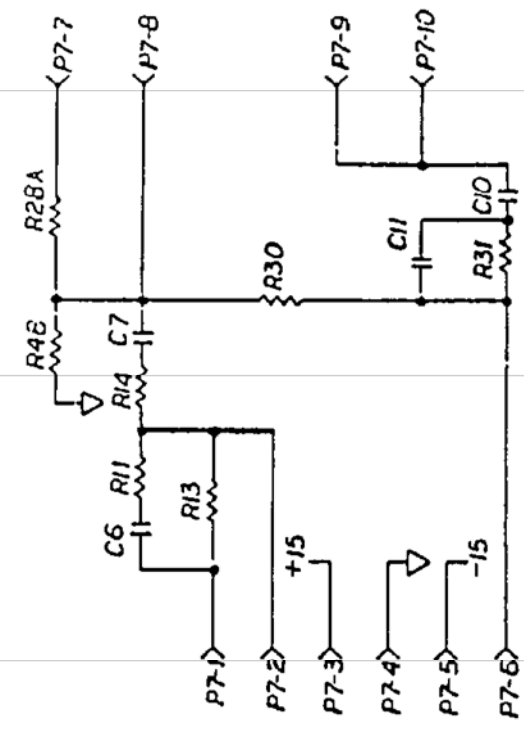
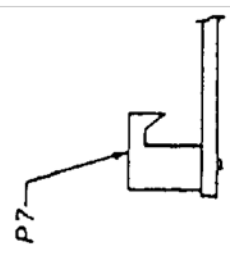

A11

FOR ELECTRICAL PARTS LIST SEE EPL 33035

DATE	REVISED	BY	REASON
FIXED COMPENSATION BOARD			
A 721 z			
DA	15	RE	1
33035			1

WESTAMR  
1866708000  
1042 1874 STREET  
MILWAUKEE, WIS.  
33035

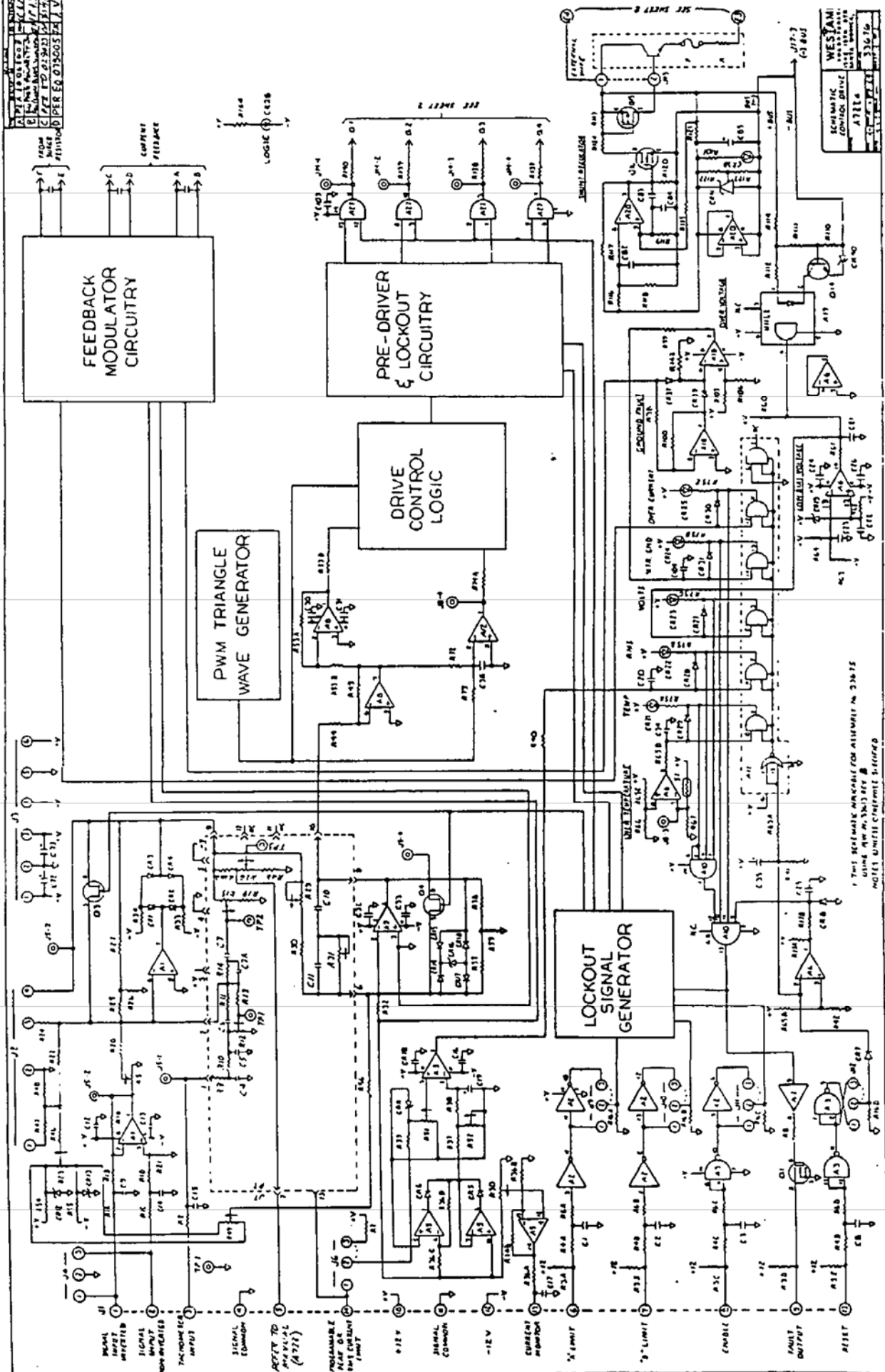

1	100	100
2	100	100
3	100	100
4	100	100
5	100	100
6	100	100
7	100	100
8	100	100
9	100	100
10	100	100
11	100	100
12	100	100
13	100	100
14	100	100
15	100	100
16	100	100
17	100	100
18	100	100
19	100	100
20	100	100

WESTERN SCIENTIFIC CONTROL DRIVE  
 DATE: 11/77  
 VERSION: 33676

THIS SCHEMATIC IS SUBJECT TO CHANGE WITHOUT NOTICE