

INSTRUCTION MANUAL

WESTAMP A 662 SERIES

(120 & 160 Volt)

This is a general manual describing a whole series of amplifiers and may be used in conjunction with drawings pertaining to various specific models.

CAUTION

The maintenance procedure described herein should be attempted only by highly skilled technicians using proper test equipment. Read your warranty provisions before starting, to avoid voiding your warranty.

TABLE OF CONTENTS

DESCRIPTION	PAGE
Foreword	1
Fuse Data	1
Drive Specifications (120V)	2
Block Diagram	3
Protective Features	4
Main Control Board (Simplified)	5
Two Important Definitions	5
Main Control Board (Pin + Plug Callouts)	6, 7, & 8
Power Supply Regulator	8
Installation Drawing (Discussion)	9
Typical Signal Wiring Information	10
Installation Drawing (Sample)	11
Interface Board (Simplified)	12
Servo System Compensation	13 & 14 & Last Page
Tapered Current Limit (Simplified Procedure)	15
Tapered Current Limit (More Detailed Procedure)	16, 17, & 18
Main Control Board (Parts Callout)	19
Interface Board (Parts Callout)	20
Drive Schematic	21 & 22
160V Specification	23

CAUTION: IN VARIOUS LOCATIONS IN THIS MANUAL THERE ARE TWO DIFFERENT VOLTAGES CALLED OUT WHEN THE BUS POWER IS DISCUSSED. THE LOWER VOLTAGE IS FOR THE 120 VOLT MODELS AND THE HIGHER VOLTAGE IS FOR THE 160 VOLT MODELS.

FOREWORD

This manual is a general purpose manual, covering the theory of operation in block diagram form. Along with Installation Drawing, Set Up Procedure, and application of the A662 Series of Pulse Width Modulated Servo Amplifiers.

The manual does not necessarily apply to any individual amplifier. However, the information is presented in a general way so that it may be applied to a specific amplifier in conjunction with its associated drawings.

The A662 Series of Pulse Width Modulated Amplifiers consist of a single chassis containing the following:

1. An interface board which mounts to a control board and contains adjustable system compensation and may contain adjustments for scaling the current proportional to output voltage (tapered current limit).
2. A control amplifier board which contains the control circuits.
3. Two output power sections which contain the output transistors.
4. The chassis contains the bias power supply (logic power) which is plus and minus 15 volts, the main output power supply, terminal blocks for logic input, main power, and motor outputs, fuse for fan and logic power, a UL listed blower, and a regulator(regeneration) module.

FUSE DATA			
MODEL NO.	FUSE	F401	F801-4
	TYPE	MDA	MDX
A6621	1 AXIS	1 AMP	3 AMPS
A6622	2 AXES	2 AMPS	3 AMPS
A6623 & 4	3 or 4 AXES	3 AMPS	3 AMPS

MODEL # BUS VOLTAGE
A6621-12 120 VOLTS
A6621-16 160 VOLTS

NOTE: Look at the nameplate on chassis.

SPECIFICATIONS:

A662

- 1) Peak Current ±40 Amps
- 2) Peak Output Voltage (Typ) ±120 VDC
- 3) Continuous Current ±20 Amps
- 4) Continuous Output Voltage (Typ) at continuous current. ±112 VDC
- 5) HP Rating (Continuous) 3.0 HP
- 6) Form Factor 1.01 at Full Current
- 7) Switching Freq. (Const.) 2 KHz
- 8) Input Voltages Bus 65 to 85 VAC. Bias
120 VAC RMS @ 2 Amps
50/60 HZ Single Phase
- 9) Frequency Response 500 Hz Min
- 10) Dead Band None
- 11) Gain Adjustable - 22 Turn Pot
 - Input 1 (Signal) Differential/
or Single Ended 0-6000 A/V (Min)
 - Input 2 (Tach) Single Ended 0-6000 A/V (Min)
 - Input 3 (Aux) Single Ended 0-6000 A/V (Min)
- 12) Signal Input Impedance 20 K Minimum
- 13) Signal Input Voltage
 - Typical -10 Volts
 - Maximum ±50 Volts
- 14) Drift (Referred to Input) 10 μ V/°C
- 15) Current Limit (22 Turn Pot) Adjustable/Programmable
- 16) Signal Balance (22 Turn Pot) Adjustable
- 17) Ambient Temp (Operating) 0-50°C
- 18) Auxiliary Inputs Gain Reduction
Limit Switch Overtravel
(NO or NC)
Remote on-off (Electronic)
Programmable Current Limit
- 19) Auxiliary Outputs Output Current Monitor
10V = 100% I PK
±15 VDC @ 50 MA
Remote Fault Indication
(Open Collector Output)
- 20) System Compensation Adjustable and Built in
- 21) Protection : Individual LED Indication For Each Condition
 - a) Shorts to ground either leg
 - b) Shorts across output
 - c) RMS overload (electronic)
 - d) Bias status
 - e) Bus status
 - f) Overvoltage indication
 - g) Overtemperature
 - h) Remote off
- 22) Protection : No LED Indication
 - a) Current Limit
 - b) Fuse For Bias and Fans
- 23) Cooling Blower
- 24) Weight 11 lbs *
- 25) Mounting Panel (Vert/Horiz)
- 26) Power Transformer Separate. May be supplied
by customer, if desired.
- 27) Options Shunt Regulator
Tapered Current Limit

NOTES:

- 1. Maximum peak current is for 1 second.
- 2. Freq response is typical of the amplifier with no compensation. System compensation in most applications usually reduces the response.
- 3. Consult factory concerning application requiring continuous regeneration.
- 4. 120 VAC is for blower and bias power.
- 5. Output voltage max is from 85 VAC RMS bus power.
- 6. Amplifier provides a range of output voltages depending on input bus voltages.
- 7. If motor has 4.0 mHy no external inductor is necessary.
- 8. Output current monitor can drive 5K or more load.
- 9. If any RED LED is on, this indicates a trip of fault logic or a remote off indication. Remove bias power, look for fault and/or wait 10 seconds to reapply bias power. Amplifier will start if fault has cleared.

MODEL	NO. OF AXES	CHASSIS SIZE ** (Inches)		
		L	W	H
A6621	1	17 1/2	6	7 1/4
A6622	2	17 1/2	11	7 1/4
A6623 or 4	3 or 4	17 1/2	15.5	7 1/4

* 1 Axis Chassis without transformer & inductor

** Includes Power Supply & (Regulator)

DESCRIPTION OF A662 BLOCK DIAGRAM

The A662 amplifier consists of a close loop feedback amplifier which has a second close loop within the outer loop. Referring to the Block Diagram, analysis may begin at the signal input point at the left side of the page. The signal input comes to a summing point designated as a circle with a cross in it. The signal input and the tachometer input are of opposite polarity and are normally almost equal in magnitude. The difference between the signal input and the tachometer input becomes an error signal which is amplified in the amplifier designated A1.

The output of A1 is a command to the inner loop. The feedback to the inner loop summing point is from a motor current sense circuit which is sensing output current to a motor. Again there is an error signal which is the difference between the command and feedback signal. This error signal is amplified by A9.

The amplified error signal from A9 goes to two comparator modulators whose other inputs come from a triangle wave generator. If the A9 output goes positive, one comparator modulator puts out wider and wider pulses at the frequency of the triangle wave generator. If the A9 output goes negative, the other comparator modulator puts out wider and wider pulses.

One comparator modulator causes the motor to run in one direction. The other comparator modulator causes the motor to run in the other direction. Each comparator modulator goes to a fault gate and bridge driver which in turn drives the output bridge if no fault has occurred.

The output bridge delivers rectangular voltage pulses to an external choke which in turn is connected to a motor. Because the choke has inductance, the motor current increases while the voltage pulse is present and decreases while the voltage pulse is missing. The output bridge includes diodes which carry the motor current while the output transistors are turned off.

The fault sensor measures current to the bridge from the power supply through a resistor. If excessive current is sensed, the fault sensor activates the fault gate and turns off the bridge.

Other faults which may turn off the output bridge are due to exceeding the RMS output current, over temperature, low or high bus voltage, low bias voltage, short (internal/external), motor ground, and remote. Remote fault turns on whenever a fault occurs and may turn off other amplifiers in the system if the amplifiers are interconnected properly. Usually if the Remote LED indicator is on by itself it indicates that this amplifier has been shut down from an outside cause.

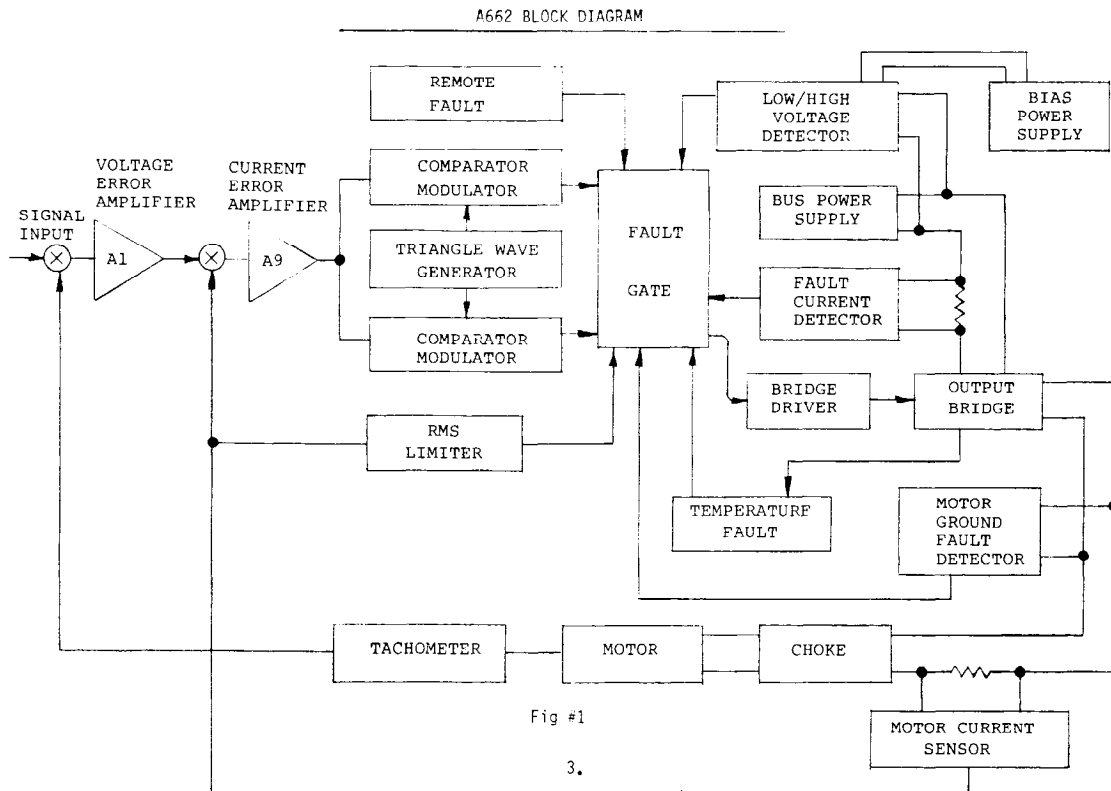

PROTECTIVE FEATURES - LED DISCUSSION

The A662 amplifier has many advanced safety features

These safety features help protect personnel, machinery, and the amplifier from accidents.

The amplifier provides 8 indications of its status. These are as follows:

- Bias Status - Green LED indicates the presence of Logic Voltage. However this LED does not indicate the level of ± 15 volts. See Voltage LED for further discussion.
- Bus Status - Yellow LED indicates the presence of Bus Voltage. However the LED does not indicate the level of Bus Voltage. See Voltage LED for further discussion.
- Remote - Red LED indicates the drive has been shut down externally or by an internal fault. This LED provides information simultaneously along with another condition indicator.
- RMS - Red LED indicates the RMS current of the amplifier has been exceeded. The drive will trip off and stay off when the RMS has been exceeded. Remote LED will be lit when RMS LED is lit.
- Temp - Red LED indicates the amplifiers output sections have become too hot. The temperature for tripping is 85^o C. Remote LED will be lit when Temp LED is lit.
- Voltage - Red LED. This can be from any one or a combination of the following:
 - a) Indicates Bus Voltage too low below 84 VDC. (112)
 - b) Indicates Bus Voltage too high above 145 VDC (195) - will occur if regulator fuses have blown.
 - c) Indicates Bias Voltage too low - if the sum of the Bias Power is less than approximately 28 Volts. The amplifier will latch off even if a momentary condition occurs.Remote LED will be lit when Voltage LED is lit.
- Short - Red LED indicates that an internal surge current was present inside the amplifier. This may occur due to either or both of the following:
 - a) An output transistor becoming damaged.
 - b) One of the output terminals of the amplifier grounded.Remote LED will be lit when Voltage LED is lit.
- Motor Gnd - Red LED indicates that either one of the motor wires has become grounded, or partially grounded, due to faulty wiring, armature of motor shorting to ground, motor arcing. Remote LED will be lit when Motor Gnd LED is lit.

NOTE: Under all conditions, except when Remote LED is lit by itself, when unit trips off due to a fault condition, it is necessary to remove Bias Power to reset the system. Please remember the sequence to start drive is Bus Power first - then Bias Power. Bus and Bias power may also be applied simultaneously.

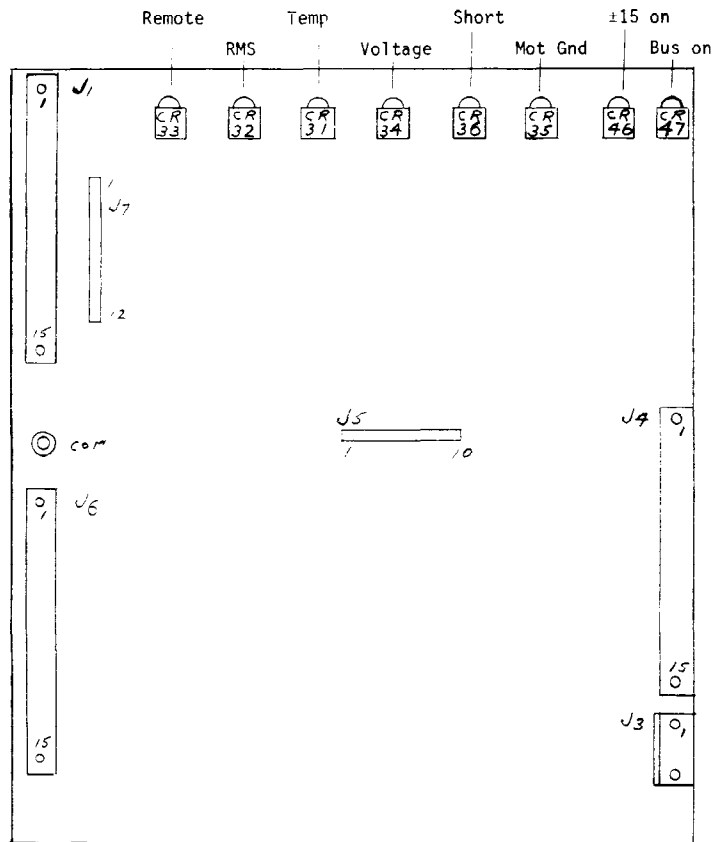

MAIN CONTROL BOARD

Fig #2

IMPORTANT DEFINITIONS:

Non-Latching Type - When the condition that has caused the particular output to go to its on state has been removed, the latch is automatically reset and restored to original operating condition.

NOTE: In some cases, this means amplifier will come back on line - be careful.

Latching Type - When the condition (that has caused the particular output to go to its on state) has been removed, the output will remain in its on state. It is necessary to shut the ±15 Volt logic power off for the latch to get reset.

Connector J-1

- Pin 1 - Inverting signal normally used for the differential input. A positive signal provides a negative signal to the main velocity control op amp. This signal would not normally be used in single ended operation. However, if Pin 1 is used you do not have to ground Pin 2 of J1 because it is already connected to ground through a resistor.
- Pin 2 - Non inverting signal normally used as the other half of the differential input. A positive signal provides a positive signal to the main velocity control op amp. This is the signal input that should be used if single ended input is required. [DON'T FORGET TO GROUND PIN 1 TO PIN 4 IF PIN 2 IS USED AS SINGLE ENDED BECAUSE THE SIGNAL BEING FED INTO PIN 2 WILL BE REDUCED BY A FACTOR OF 2.]
NOTE: Using a differential front end provides a high degree of noise rejection capability.
- Pin 3 - Tach signal input-single ended.
- Pin 4 - Signal common ground for tach and (signals when single ended inputs used).
- Pin 5 - Aux signal input - single ended.
- Pin 6 - Spare not used.
- Pin 7 - Spare not used.
- Pin 8 - Remote shut-down, Normally ungrounded.
When Pin 8 is connected to a common like Pin 9, the drive will shut off with Remote LED indication. This is a non latching type input. Same feature as on J6 Pin 12.
- Pin 9 - Common like Pin 4.
- Pin 10 - +15VDC bias power, 50 MA is available for external use.
- Pin 11 - Common - bias power.
- Pin 12 - -15VDC bias power, 50 MA is available for external use.
- Pin 13 - Remote current limit - Provides the ability to externally adjust current limit by installing appropriate resistor to common.
- Pin 14 - Common
- Pin 15 - Output current monitor 10V = Maximum current specified for amplifier. Capable of driving 5K or more load such as a meter with respect to common.

Connector J-2 - See Interface Board Section.

Connector J-3

- Pin 1 - +15VDC bias power.)
- Pin 2 - Bias common.)----- These pins are used to bring ±15 Volts into main control board.
- Pin 3 - 15VDC bias power)
- Pin 4 - Multi-axis shut-down - Normally ungrounded. In a multi-axis system all Pin 4 terminals should be connected together in parallel. If a fault occurs on any one axis, all axes will shut down.
NOTE: Non latching output. If fault has cleared, all axes connected in this manner will be enabled.

Connector J-4 - Interconnect assembly between logic and power section. Do not disturb.

Connector J-5 - Internal monitoring points in unit.

Connector J-6

NOTE: Referencing Pins 1, 2, 3, 4, 5 & 6.

These outputs normally are at zero volts and must have an external pull up resistor connected to a plus voltage of less than 30VDC.

These outputs are capable of pulling down an external pull up component.

For example - A TTL load or 24 Volt logic. Current capacity pull down 10 MA.

- Pin 1 - Remote - Provides information that the drive has been shut down externally or by an internal fault condition. This output provides information simultaneously with other condition indicators - Non-latching output
- Pin 2 - RMS - Provides information that the continuous rated RMS current of the drive has been exceeded - Latching output.
- Pin 3 - Temp - Provides information that the rated temp of the unit has been exceeded. Normal trip level of this sensor occurs at approximately 85°C - Latching output.
- Pin 4 - Mot Gnd - Provides information that either one of the amplifier's output terminals has become grounded - - Due to faulty wiring, motor arcing, armature of motor shorting to ground - Latching output.
- Pin 5 - Voltage - Provides information about voltages.
- a) Bus voltage below 84 VDC (120V Model) - 112 VDC (160 Volt Model)
 - b) Bus voltage above 145 VDC (120V Model) - 195 VDC (160 Volt Model)
 - c) Bias voltages too low if the sum of the Bias power is less than approximately 28 volts
- Latching output.

NOTE: To convert VDC from VAC ($VAC\ RMS \times 1.414 = VDC$)

- Pin 6 - Short - Provides information that an internal surge current was present inside the amplifier. This may have occurred due to:
- a) An output transistor shorting.
 - b) One of the output terminals of the amplifier has become grounded.
 - c) Faulty wiring before the output inductor.
- Latching output
- Pin 7 - Common
- Pin 8 - Remote Shut-Down, Normally Grounded. This point can be used to remotely shut off drive - non latching output.

NOTE: Pin 8 must be connected to Pin 7 if not used, otherwise drive will not deliver any power

Pins 9

- & 10 - Limit switch overtravel - Normally Grounded

These outputs are used to prevent the amplifier from producing any output current when either of these pins are removed from ground. These outputs are usually used in conjunction with machine normally closed limit switches.

For use with Differential Input

If J1-2 input is positive with respect to J1-1 input then TB403-1 goes positive with respect to TB403-2 [Lets say Motor goes cw].

If the cw rotation is to be inhibited open J6-9 with respect to common. (J6-11)

Opening J6-10 with respect to common will inhibit the opposite output/rotation - say ccw

For use with Single Ended Input

If J1-2 input is positive with respect to J1-4 then TB403-1 goes positive with respect to TB403-2 [Lets say Motor goes cw].

If the cw rotation is to be inhibited open J6-9 with respect to common (J6-11)

Opening J6-10 with respect to common will inhibit the opposite output/rotation - say ccw.

NOTE: Pins 9 and 10 must be connected to Pin 11 if not used, otherwise amplifier will not deliver any power - Non Latching output.

Pin 11 - Common

Pin 12 - Remote Shut Down, Normally Ungrounded

Pin 12 provides the same function as Pin 8 of J6 except it is the opposite polarity. If you want the amplifier to stop putting out power connect Pin 12 to common (J6-11)

Pin 13

& 14 - Limit Switch Overtravel Normally Ungrounded

Pins 13 and 14 provide the same functions as Pins 9 and 10 of J6 except they are the opposite polarity. Pin 13's counter part is Pin 9. Pin 14's counter part is Pin 10

If you want the amplifier to stop putting out power you must ground Pin 13 or 14. These pins are usually used in conjunction with machine normally open limit switches.

See the explanation of grounding appropriate pin to prevent amplifier output under Pins 9 & 10 in J6 section.

Non Latching output

Pin 15 - Multi-Axis Shut Down - Normally Ungrounded

In a multi-axis system all Pin 15 terminals should be connected together in parallel.

If a fault occurs on any one axis, all axes will shut down. Pin 15 is the same as J3-4

NOTE: Non Latching output. Remember if fault has cleared, all axes connected in this manner will be enabled.

NOTE: Pin 15 of J6 has the same function as Pin 4 of J3.

Connector J-7

Interconnection between Interface board and Main Board

Power Supply Regulator (Shunt Regulator)

During the slowing down or stopping of a D.C. Motor, the motor regenerates. This energy is put back into the system. The system absorbs this in the form of pumping up the supply voltage capacitor.

The regulators function is to keep the supply voltage at a safe level by automatically connecting or disconnecting one or several dumping resistors across at main supply capacitors. This regulator is protected against excessive dissipation by means of a fuse (s). Model A662 has a regulator as standard.

INSTALLATION:

Each amplifier in the A662 Series comes with an individual installation drawing showing where to make the various connections for power input, signal input, tachometer input, fan and bias power input and output to the motor. While this manual may show in a general way how to make connections to amplifiers, it is imperative that the specific instructions applicable to your amplifier are followed. Always be certain to apply the correct input power voltage and frequency. The input power transformer for all the amplifiers in the A662 Series are separately mounted. It is possible to use one power transformer for several amplifier units if that transformer is sized properly. These transformers may have dual voltage primaries and, in such cases, make certain that the jumpers are on the correct transformer terminals for your input AC power source. On all amplifiers the motor output is taken from separate terminals mounted on TB403

CAUTION: DO NOT USE GROUNDED TEST EQUIPMENT ON THE OUTPUT CIRCUITS AND DO NOT CONNECT EITHER OF THE OUTPUTS TO GROUND.

The signal input is usually applied directly to Pin 2 of J-1 and the signal common is usually applied to Pin 4 of J-1. The tachometer signal is usually applied to Pin 3 of J-1 and the tachometer return is connected to Pin 4 of J-1. The auxiliary signal is applied to Pin 5 and the auxiliary signal return is applied to Pin 4. Use shielded wires for signal and tachometer inputs to prevent stray pickup noise being introduced into the amplifier. The amplifier may have a bandwidth anywhere from 500 Hz (no compensation) to a much lower frequency, depending upon the setting of the TC (time constant) potentiometer and the components in the servo compensation network. Figure 3 shows a typical installation drawing that could be used to test an amplifier-motor combination.

In many cases, an inductor is connected in series with the output of the amplifier and the motor. This inductor is required if the inductance of the motor is below recommended value - See Specification Sheet, Page 2. The amplifiers in this series require up to 2 amperes of 120 VAC for the fan and power bias which are Terminals 1 and 2 of TB-401. In addition, the output voltage from the secondary of the transformer may be anywhere from 65 volt(87) volt RMS to 85 volt(113)volt RMS in accordance with the maximum output voltage required. The output of the secondary of the 3 \emptyset power transformer is connected to Terminals 1, 2, 3 of TB-402. Please be sure that all the connections are proper before applying power to the unit.

NOTE: Reference J1 Pins 1 and Pin 2

To obtain the benefits of the differential input - common mode rejection capacity (common mode signals between the reference ground location and the amplifier location will be rejected).

Bring Pin 1 to system reference ground and Pin 2 to the command at the numerical control. See next page. Common mode signals result from heavy currents in ground wires.

FOR DIFFERENTIAL SIGNAL INPUT CONNECTION

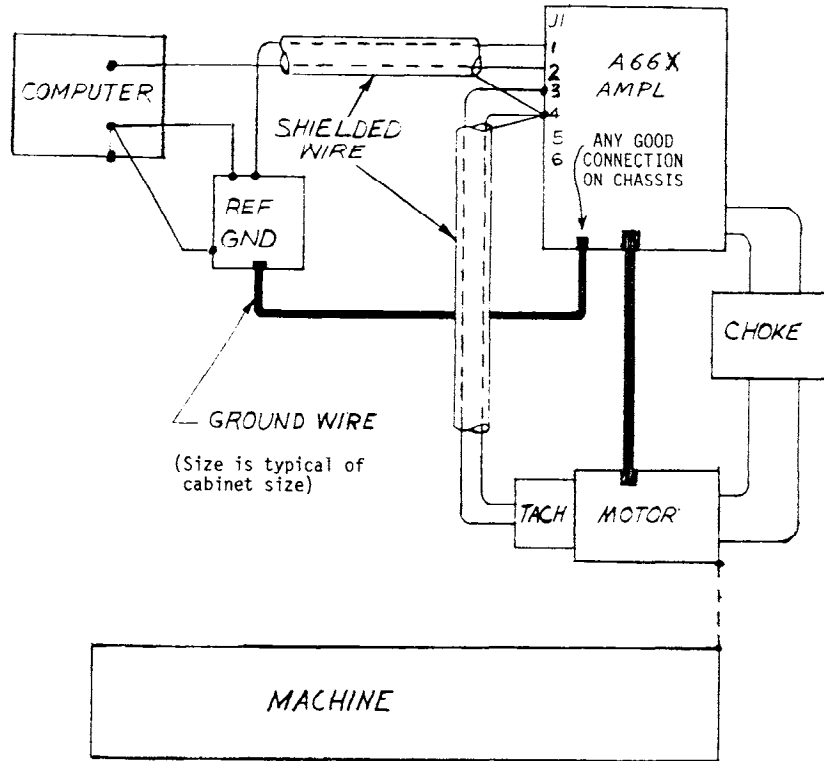

FOR SINGLE ENDED SIGNAL INPUT CONNECTION

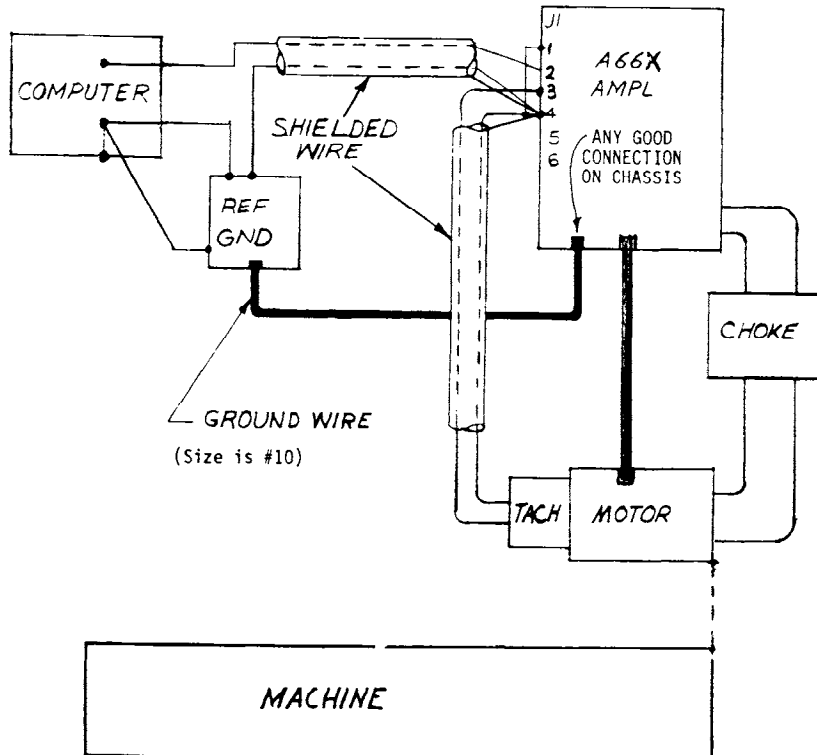

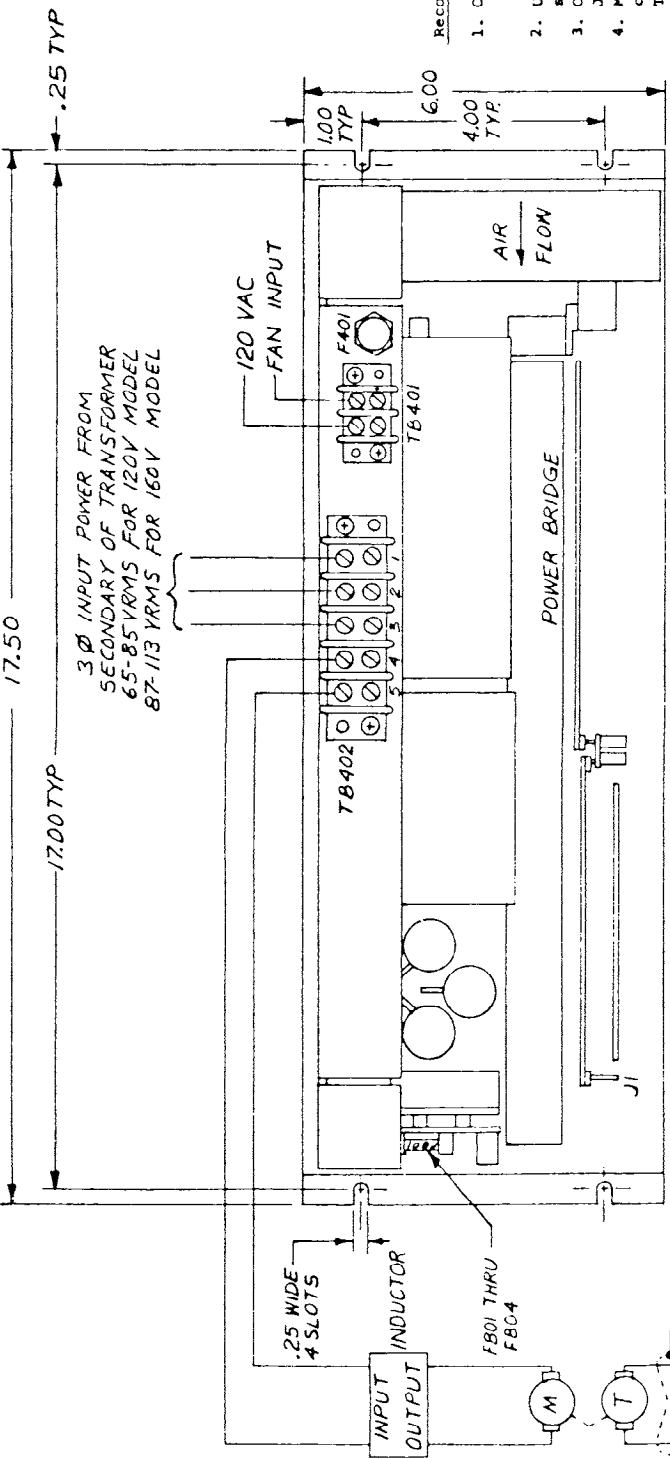

Recommended Installation Procedure

1. CAUTION : Outputs at TB402 must be isolated from all other circuits and must not be grounded.
2. Use shielded wire on signal input leads, connect shield to Signal Common at J1.
3. Output at TB402-4 is (+) w.r.t. TB402-5 when J1-1 is (+) w.r.t. J1-2.
4. Motor frame and Amplifier chassis must be connected to System Ground. Do not ground Transformer secondary.

FUSE DATA			
Model No.	F401	PR01-F804	
Fuse Type	MDA	MDA	
A6621-16 #	-4-03	1 Amp	3 Amps

* NOTE : Complete model number consists of one to three letters

CONNECTIONS AT J6

- 16-1 REMOTE INDICATOR
- 2 RMS INDICATOR
- 3 TEMP INDICATOR
- 4 MOTOR GND INDICATOR
- 5 VOLTAGE ERROR INDICATOR
- 6 SHORT INDICATOR
- 7 COM
- 8 REMOTE SHUT-DOWN, NORMALLY GROUNDED
- 9 LIMIT SWITCH, NORMALLY GROUNDED
- 10 LIMIT SWITCH, NORMALLY GROUNDED
- 11 COM
- 12 REMOTE SHUT-DOWN, NORMALLY UNGROUNDED
- 13 LIMIT SWITCH, NORMALLY UNGROUNDED
- 14 LIMIT SWITCH, NORMALLY UNGROUNDED
- 15 MULTI-AXIS SHUT-DOWN

PART NO. INDICATION MATERIAL LETTER

UNLESS OTHERWISE SPECIFIED, TOLERANCES FRACTIONS 2/1000 ALL DIMENSIONS TO UNLESS OTHERWISE SPECIFIED

WESTAMP INCORPORATED 1542 15TH STREET SANTA MONICA, CAL.

INSTALLATION DRAWING

MODEL A6621

DATE 11-1-51

32150

REV 3

2 AMPLIFIER MAX HEIGHT IS 7.25

J6-1 THRU J6-6 NORMALLY DRIVE TTL INPUTS (NORMALLY LOW)

NOTES: UNLESS OTHERWISE SPECIFIED

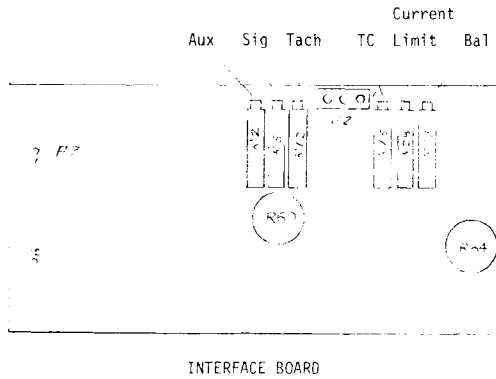

Fig. No. 4

Connector J2

Pin 1

& 2 - May be connected together to reduce gain around the velocity control amplifier.

Pin 1

& 3 - May be used for an external programmable current limit by installing an appropriate resistor for the desired current.

ADJUSTMENTS:

Figure 4 shows the location of various adjustments on the circuit board. These adjustments are as follows:

Aux Gain - The auxiliary gain potentiometer R₂ is used as an additional signal input. If this input is not used, turn this pot fully "CCW".

Sig Gain - The signal gain potentiometer R₅ is used to set the signal gain of the system. Turning R₅ "CW" increases the signal gain.

Tach Gain - The tach gain potentiometer R₁₂ is used to set the amount of tach feedback in the closed loop system. This potentiometer also affects the stability of the tach (velocity) loop. Turning R₁₂ "CW" increases the tachometer gain.

Balance - The balance potentiometer R₂₃ is used to adjust the offset. It may be necessary to adjust the balance for zero output when zero input command is applied. This adjustment should be done after the tach and signal potentiometers are set to their final positions.

TC - The TC (time constant) potentiometer is R-15. The TC potentiometer is used to help stabilize the closed loop system. "CW" rotation increases the bandwidth.

Cur Lim - The current limit potentiometer is R-28. If the current limit potentiometer is at the maximum "CW" position, then the unit puts out its maximum rated peak current. If it is desired to decrease the peak output current of the amplifier, turn the Cur Lim potentiometer in a "CCW" direction to reduce the peak output current.

Tapered Current Limit

R-60 and R-64 - These two potentiometers are used to adjust the tapered current limit. All amplifiers in this series may or may not have these two pots. When these pots are fully "CCW" their affect on changing the current with speed is reduced. Further discussion is covered in the tapered current limit section.

The proper procedure to be followed in setting up this unit in your servo system will be explained in a Short Form Set Up Procedure which follows:

SERVO SYSTEM COMPENSATION:

It is possible to compensate a servo system empirically without any theoretical evaluation of the system, provided that the specifications are not too stringent. For most applications, the procedure as outlined in the Short Form "Set Up Procedure" will result in adequate servo performance. The A662 Series of servo amplifiers were designed to operate with "state of art" characteristics in modern performance oriented systems. Therefore, matching amplifier-motor-tachometer combinations are recommended. However, the A662 Series amplifiers will provide good performance with many D.C. motor-tach combinations, accompanied by merely adjusting the TC and the tach gain potentiometers.

SHORT FORM SET UP PROCEDURE (All PWM Amplifiers)

1. Connect in accordance with proper Installation Drawing.
2. Check input voltage and proper transformer connections.
3. Note: All adjustment pots are 22 turns nominal.
4. Before turning power on, adjust all pots as follows:
 - a. Current limit pot - ccw all the way out.
 - b. "TC" pot - mid-range 11 turns from either end.
 - c. Tach pot - turn fully "ccw" then turn "cw" 5 turns.
 - d. Signal gain pot - turn approx. mid-range, 11 turns from either end.
5. Apply power but do not apply an input signal.

Note: For A66X Series. Main bus power must be turned on ahead of or at the same time as the bias power.
6. To check phasing of the tachometer and motor: turn current limit pot cw very slowly. If motor starts to run away, remove power and correct phasing of the motor-tach combinations.
7. Turn power back on and repeat Item 6. (Do not consider drift) Turn current limit pot to desired current.

Pot setting produces currents as shown in example.

Example: 3 turns cw = 33% Peak Current
6 turns cw = 66% Peak Current
9 turns cw = 85% Peak Current
13 turns cw = 96% Peak Current
8. If motor rotates slowly or drifts, adjust signal balance pot either way until motor stops moving.
9. Still with no input signal, turn "TC" pot "cw" until motor starts to oscillate at a high frequency, then back off ccw until this oscillation stops. Then approx. 1 - 2 turns further ccw.

Note: Some of the units have a resistor in series with the TC pot so you may not be able to break the system into an oscillation. Look at schematic and short out this resistor R-19 on A66X Series if you need more bandwidth.
10. IMPORTANT - IF TC IS FULLY CCW & SYSTEM IS STILL OSCILLATING AT HIGH FREQ. SEE NOTES ON NEXT PAGE.
11. Apply a small signal and observe motor shaft.
12. Increase or decrease tach gain pot for desired results.
 - A) Increasing tach (turn pot cw) provides quicker settling time (higher bandwidth).
 - B) Decrease tach (turn pot ccw) provides slower settling time (lower bandwidth).

Note: Settling time is not to be confused with accel or decel time, but is the time just before reaching set speed.
13. After you are satisfied with tach response do not change the tach pot anymore.
14. If motor drifts, it may be necessary to re-adjust signal balance pot.
15. Run the motor at some higher speed and watch and listen to it. If it runs smoothly, the system is OK. A rough sound means either TC is still too far cw or tach is too far cw.
16. Set the appropriate speed of the system by turning signal gain pot. CW will make system go faster for same voltage into unit. Recheck balance.
17. No further adjustments are necessary. (STOP)
18. Record the potentiometer settings on last page of manual for future reference.

MORE DETAILED SET UP PROCEDURE

If your system requires more accurate tach adjustment.

- 1) Go thru steps 1-10 on previous page.
- 2) Then apply a small signal until motor rotates and watch tach signal on an oscilloscope.

NOTE: Refer to Helpful Hints Section.

- 3) If tach loop is overdamped, turn tach pot cw until one overshoot appears. The system is now set up for maximum bandwidth in tach loop.
- 4) If you don't want an overshoot in your tach loop, turn tach pot ccw until the overshoot disappears.

NOTE: One overshoot in tach loop does not necessarily mean the position loop will overshoot.

- 5) IF THE SYSTEM IS NOT YET PERFORMING PROPERLY AND IS MECHANICALLY SOUND, SEE ATTACHED NOTES.
- 6) Also, if motor drifts, it may be necessary to re-adjust signal balance pot until motor stops.
- 7) After you have made the above adjustments, you will have to re-calibrate signal gain pot to obtain proper output voltage to input signal.
- 8) All other adjustments are factory set and do not require any further adjusting.

CAUTION: MAKE SURE POWER IS OFF WHEN SOLDERING ON CIRCUIT BOARDS.

- NOTES:
- 1) Check system for backlash, wind up lost motion, misalignment, bad coupling or any other mechanical problems.
AFTER YOU MAKE ANY OF THE CHANGES BELOW, REPEAT SET UP PROCEDURE - START WITH STEP 4 ON PREVIOUS PAGE.
 - 2) High freq. oscillation (approx. 700 CPS) even though TC pot fully ccw (high freq. oscillation probably motor resonance). Increase C7 to approx. .033 mfd and add C3=2 mfd and C5 = .022 mfd.
 - 3) If system requires more DC gain
 - a) Increase C6 to approximately .1 mfd and decrease R11 to approx. 2K. You might have to increase C7 to approximately .033 mfd - Reference Note 2 above.
 - OR
 - b) Reduce value of R16 - However, balance adjust will become more sensitive.
 - 4) If the system is highly inertial, or a highly inertial motor is used, it may be necessary to change C6 and R11 - Ref. Note 3 above.

HELPFUL HINTS:

1. Tachometer should be observed on an oscilloscope where sweep speed is set at .1 seconds/centimeter and adjust the vertical attenuator to provide a convenient displacement in response to the signal input.
2. Small step input commands may be provided with a DC simulator (battery box) while observing the tach response on the oscilloscope.
3. Typical pictures you will see on oscilloscope of tach profiles.

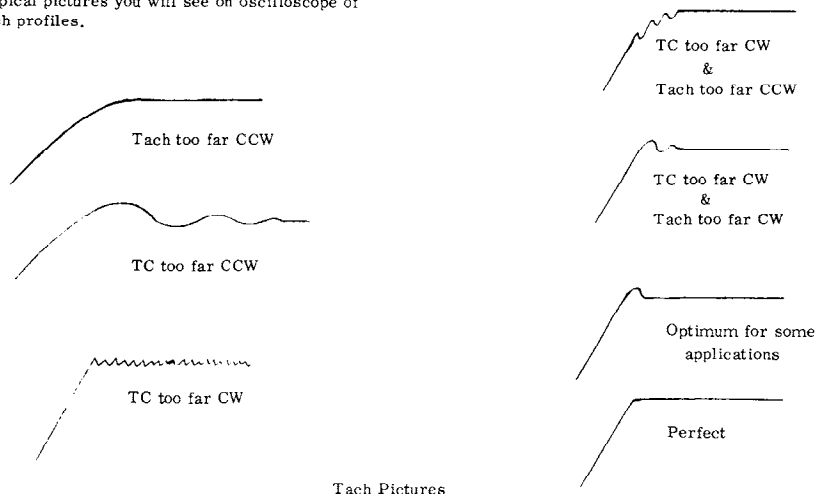

Tapered Current Limit - Option

Due to commutation capability of D.C. motors, there should be a means of reducing the motor's torque at high speeds. Otherwise, premature brush wear and/or damaged commutators will result.

Also, arcing can be developed between the commutator and motor frame creating a momentary short to ground which will shut the amplifier off.

Since we know this relationship

- a) RPM is proportional to voltage
- b) Torque is proportional to current

EXAMPLE:

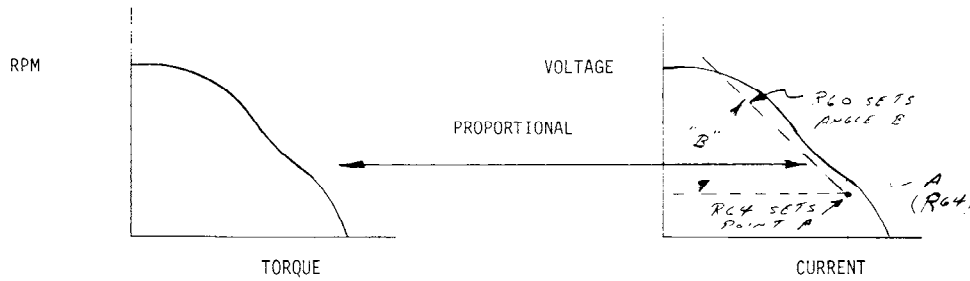

Then by shaping the amplifier's current with respect to voltage, one can safely control the commutation of a D.C. motor.

The interface board has two pots R-60 and R-64. These pots will provide a standard linear taper.

It is recommended you follow the procedure carefully so as to not damage the motor.

After Tach loop is reasonably set up using small signals, Reference "Short Form Set Up Procedure". Proceed as follows:

Simplified Procedure

- 1) Set the main current limit pot (R-28) at $\frac{1}{2}$ peak current.

Note 1 - You can get a direct read out of current by monitoring Pin 15 of J1 with respect to common.
10 Volts = maximum current of amplifier.

In Step 1 above, you should see 5 Volts on Pin 15 with respect to common for $\frac{1}{2}$ peak current.

Note 2 - We are starting off at $\frac{1}{2}$ peak current so as to not damage the motor.

- 2) Turn R-60 and R-64 fully ccw. This reduces the effect of the tapered current limit.
- 3) An initial setting of R-64 would be to set this pot to start to have an affect at 1.4 x the desired RPM. (See Point A)
- 4) The R-60 pot is used to set the slope of the taper. (Remember the starting point R-64 will affect where the slope setting ends up). (See Angle B)
- 5) Turn the main current limit pot R-28 cw to the desired current.
- 6) Provide a step function for stopping the motor and observe the current during stopping. The current should be lower at high speed and increase as the motor's speed decreases.
Note: It will be easier to see the current when motor is stopping.
- 7) If you have attained max speed and do not see any reduction in current at high speed, turn R-60 cw until you get the current where you want it.
- 8) Don't forget in doing Step 7, R-64 sets the low speed point where the taper begins on accel or ends on decel.
- 9) Note the settings of R-60 and R-64 and record for future units.

Tapered Current Limit

More detailed set up procedure.

The first step in setting the tapered current limit is to set the main scale factor resistor R56.

R56 is the select resistor and is factory selected for a motor with voltage of 100 Volts turning at 2000 RPM with a tach gradient of 31.5V/1000 RPM.

If your motor has a different BEMF (K_v) or tach gradient, then follow the example below.

What's important is, we are going to relate tach voltage to motor BEMF because we are going to look at the tach voltage for scaling.

So, a motor voltage of 100 VDC is proportional to a tach voltage of 63 VDC.

EXAMPLE:

$$\begin{aligned} R56 &= \frac{63 \text{ Volts (Max tach voltage)}}{12 \text{ Volts (Max output of an op amp)}} \\ R57 &= 12 \text{ Volts (Max output of an op amp)} \end{aligned}$$

$$\begin{aligned} R56 &= R57 \frac{(63)}{(12)} \\ &= 36K \frac{(63)}{(12)} \end{aligned}$$

$$R56 = 189K \quad \text{Select 200K}$$

NOTE: It is better to go a little higher so as not to saturate the op amp.

Sketch of the speed-torque profile, you are looking for commutation of motor and make a table like example so you know what to look for on voltage VS current.

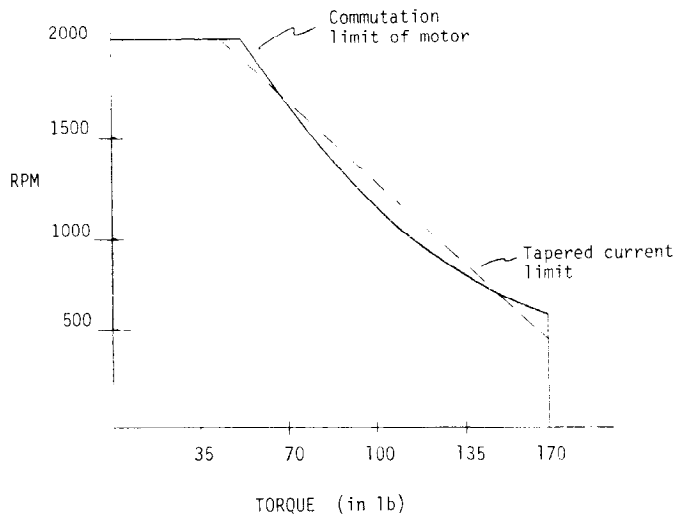

EXAMPLE:

Motor characteristics

$$K_v \text{ (Bemf)} = 50V/1000 \text{ RPM}$$

$$K_t \text{ (Torque constant)} = 4.23 \text{ in lb/Amp}$$

Amplifier characteristics

Model A662

Rated 40 amps PK

* Associated Tach Voltage At Pin 3 of J1 (Volts)	Associated Motor Voltage (Bemf)	Motor (RPM)	Max Motor Torque (in lbs)	Associated Motor Current (Amps)	* Reading at Pin 15 of J1 (Volts)
15.8	25	500	170	40	10
31.5	50	1000	115	28	6.9
47.2	75	1500	75	18	4.4
63	100	2000	35	9	2.2

* NOTE: Use each end column for further adjustments.

- 3) Set the Main Current Limit R-28 at $\frac{1}{2}$ peak current. We should be able to keep the motor's commutation under control.

This can be seen on Pin 15 of J-1 with respect to common Pin 14 of J-1 (Main Board).

- 4) You will need a 2 channel scope such as a Tektronic Model 465 that can lock the scope in its X Y plot. Set time base dial full "ccw" position - set pot in center of screen.

- 5) Set X channel (channel 1) for current Pin 15 of J-1 with respect to common (Pin 14).

NOTE: Pin 15 = 10 volts for max current of amplifier.

Suggest 5V/Division

- 6) Set Y channel (channel 2) for tach voltage Pin 3 of J-1 - It is not necessary to connect this probe to common.

NOTE: Pin 3 will be at 63 Volts for 2000 RPM (Our example).

Suggest 20V/Division.

- 7) Now provide a small step command to motor and by looking at the scope, you can see on the X axis current + Y axis speed. Don't worry about polarity.

- 8) (Picture)

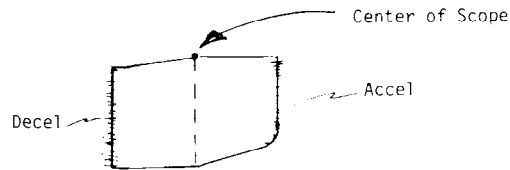

NOTE: Picture might go up and to left on accel. Depends on polarity.

- 9) Set R64 for desired RPM to start taper.

See Sketch -

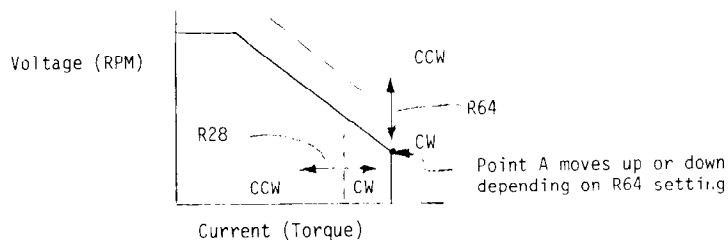

- 10) Set R60 for slope of taper

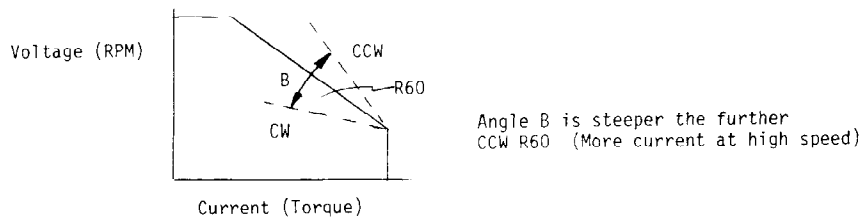

- 11) Now adjust R28 "CW" for desired level of current noting that that RPM decreases where taper starts.

FINAL PICTURE OF TAPER OPERATIONAL

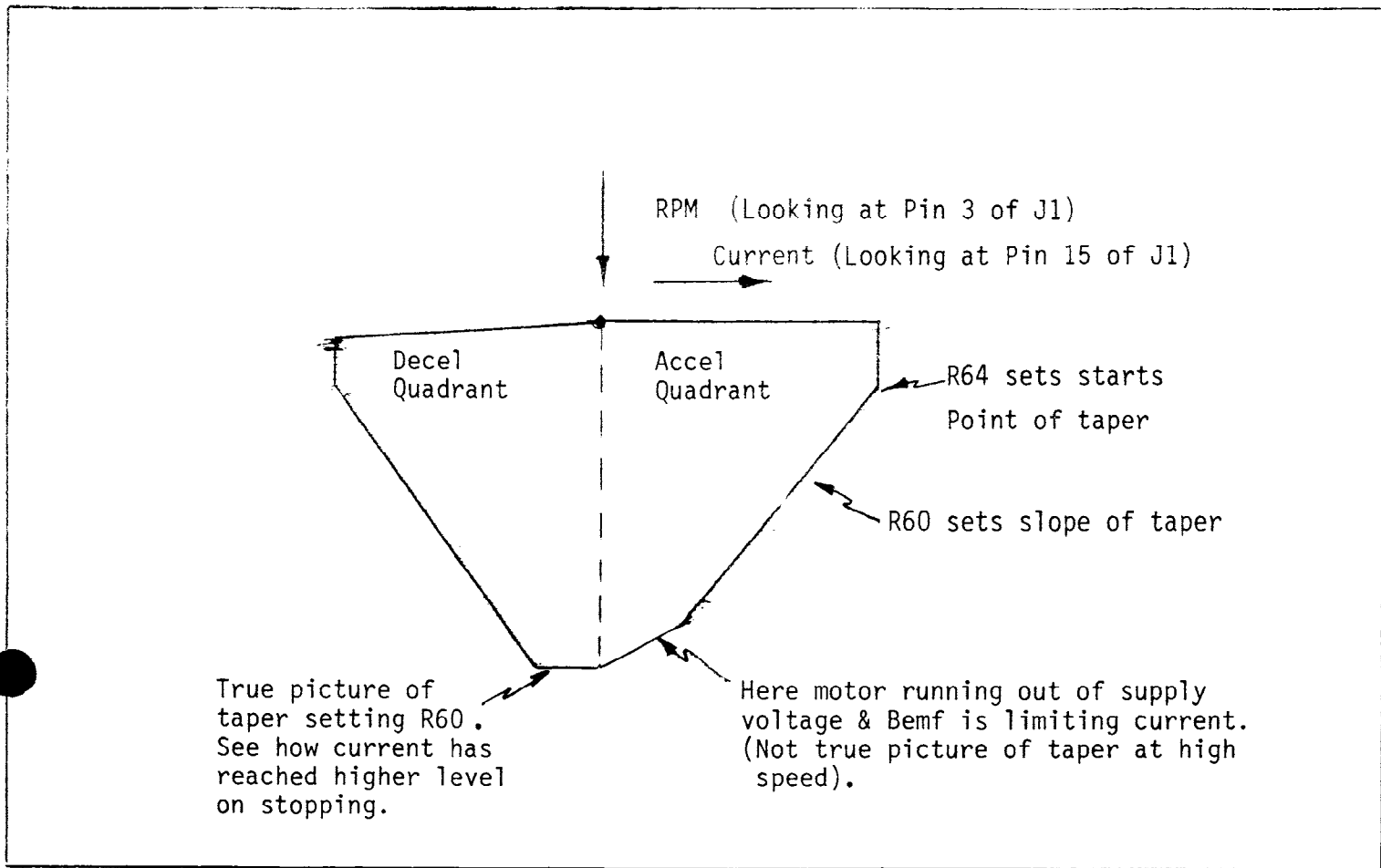

SCOPE PICTURE

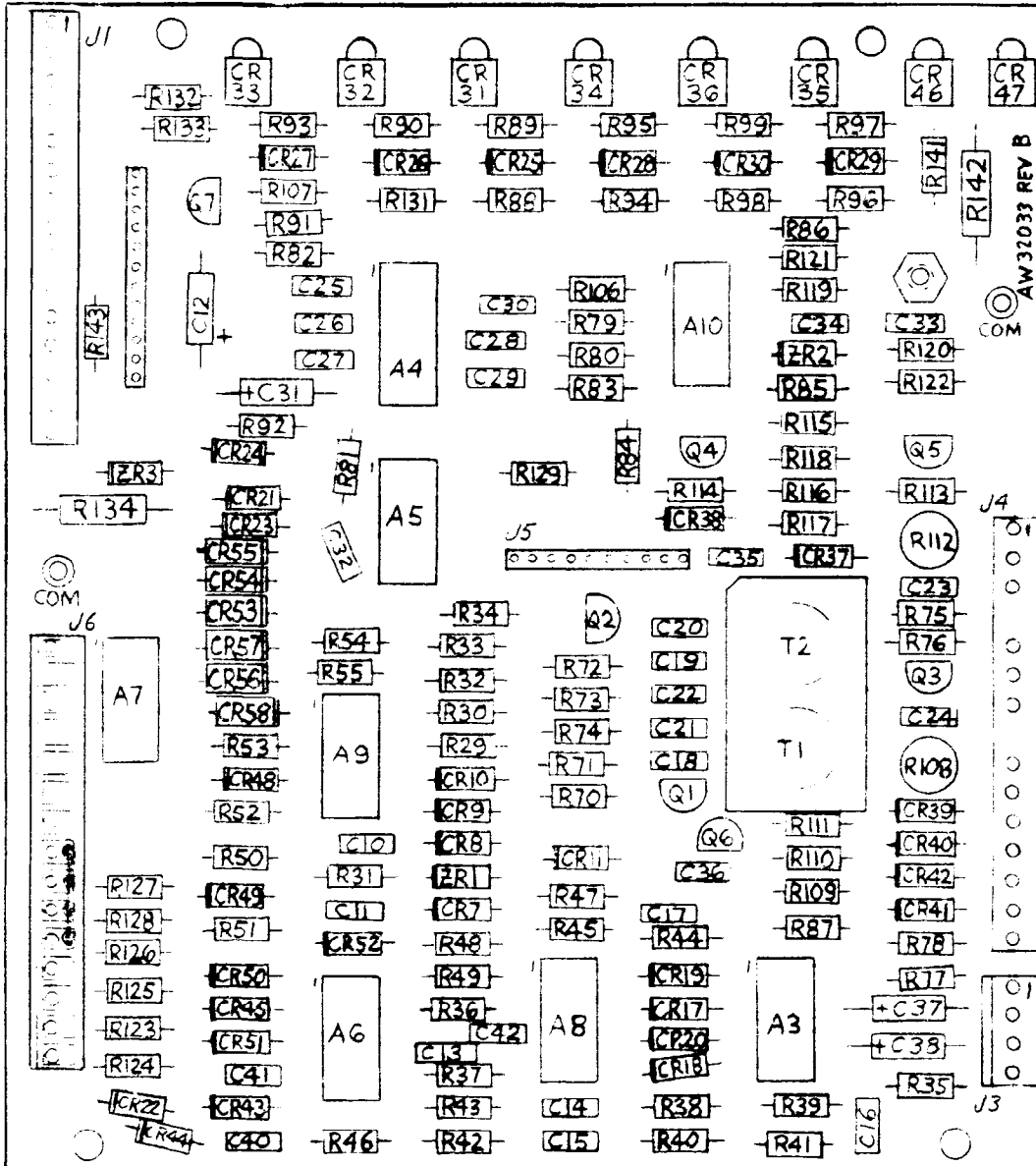

MAIN CONTROL BOARD

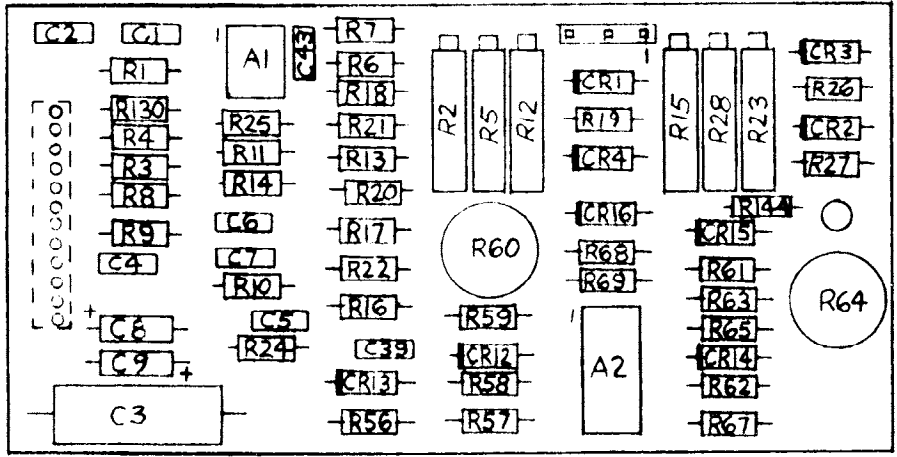

INTERFACE BOARD

-INTERFACE BOARD ASSY

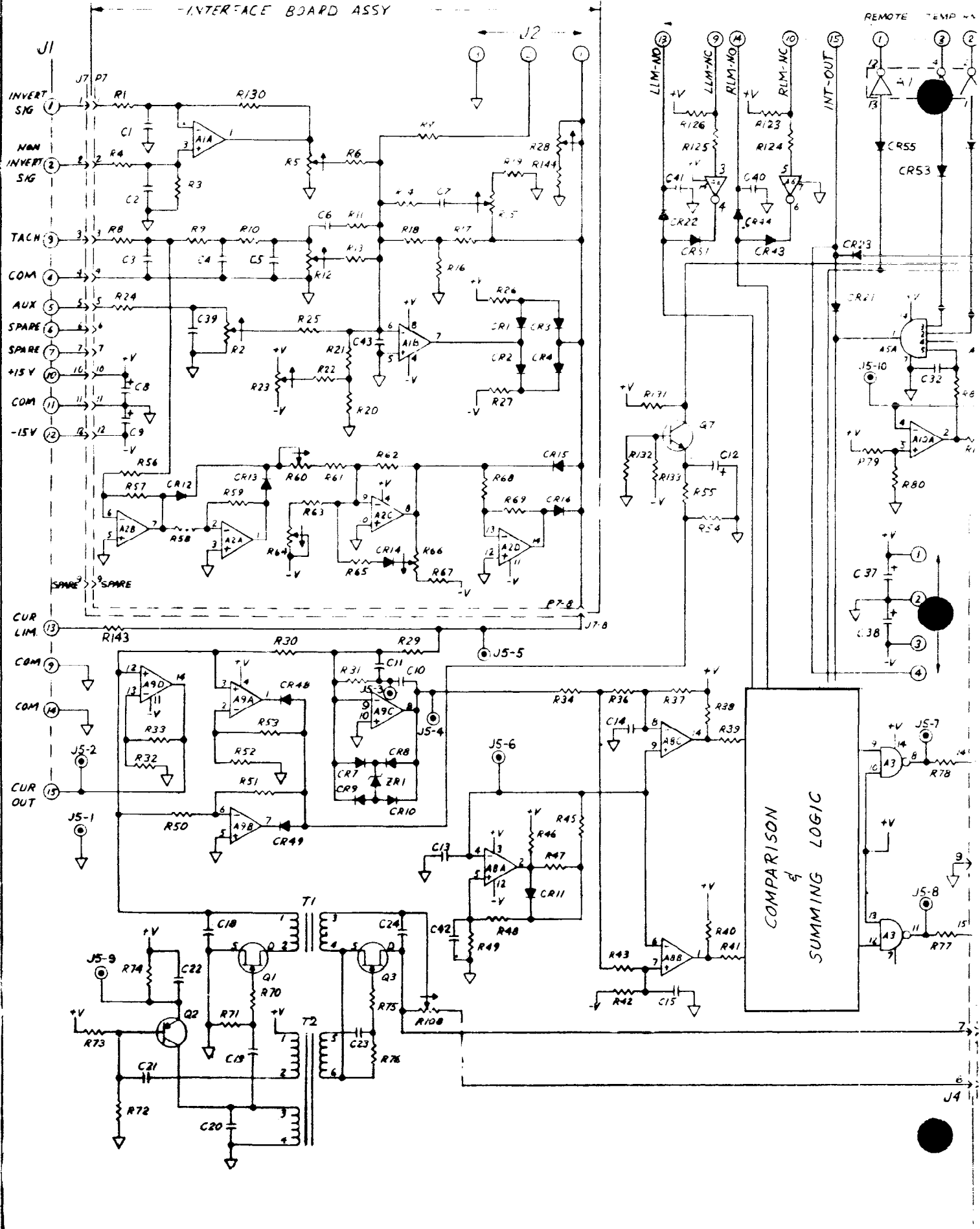

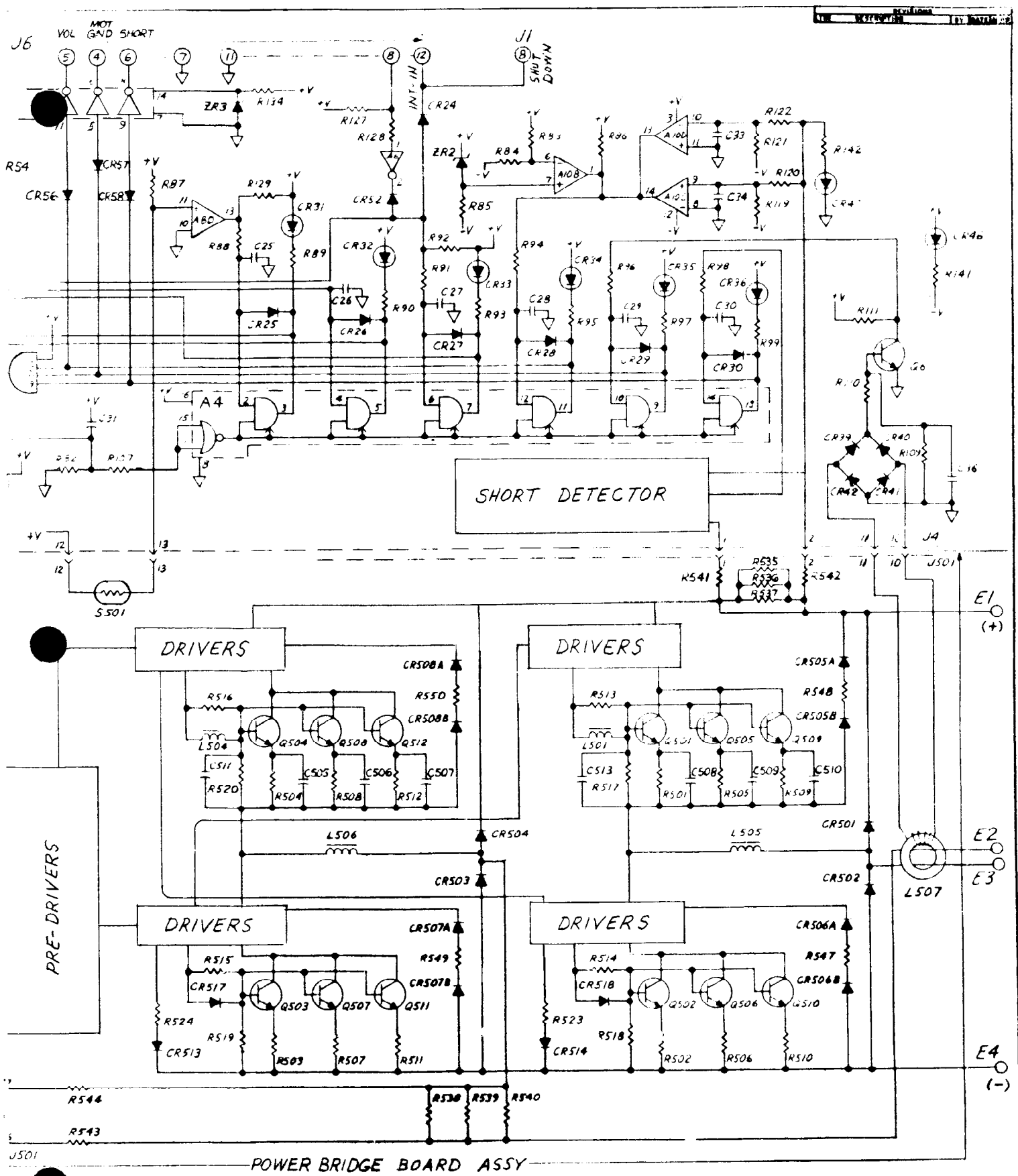

POWER BRIDGE BOARD ASSY

SCHEMATIC		WESTAMP INCORPORATED 1542 15TH STREET SANTA MONICA, CALIF
A66 X		
J.K.	DATE	A

SPECIFICATIONS:

A662

- 1) Peak Current +60 Amps
- 2) Peak Output Voltage (Typ) ±160 VDC
- 3) Continuous Current ±30 Amps
- 4) Continuous Output Voltage (Typ) ±152 VDC
at continuous current.
- 5) HP Rating (Continuous) 6.0 HP
- 6) Form Factor 1.01 at Full Current
- 7) Switching Freq. (Const.) 2 KHz
- 8) Input Voltages Bus 77 to 113 VAC, Bias
120 VAC RMS @ 2 Amps
50/60 HZ Single Phase
- 9) Frequency Response 500 Hz Min
- 10) Dead Band None
- 11) Gain Adjustable - 22 Turn Pot
 - Input 1 (Signal) Differential/
or Single Ended 0-6000 A/V (Min)
 - Input 2 (Tach) Single Ended 0-6000 A/V (Min)
 - Input 3 (Aux) Single Ended 0-6000 A/V (Min)
- 12) Signal Input Impedance 20 K Minimum
- 13) Signal Input Voltage
 - Typical ±10 Volts
 - Maximum ±50 Volts
- 14) Drift (Referred to Input) 10 μ V/°C
- 15) Current Limit (22 Turn Pot) Adjustable/Programmable
- 16) Signal Balance (22 Turn Pot) Adjustable
- 17) Ambient Temp (Operating) 0-50°C
- 18) Auxiliary Inputs Gain Reduction
Limit Switch Overtravel
(NO or NC)
Remote on-off (Electronic)
Programmable Current Limit
- 19) Auxiliary Outputs Output Current Monitor
10V = 100% I PK
±15 VDC @ 50 MA
Remote Fault Indication
(Open Collector Output)
- 20) System Compensation Adjustable and Built In
- 21) Protection : Individual LED Indication For Each Condition
 - a) Shorts to ground either leg
 - b) Shorts across output
 - c) RMS overload (electronic)
 - d) Bias status
 - e) Bus status
 - f) Overvoltage indication
 - g) Overtemperature
 - h) Remote off
- 22) Protection : No LED Indication
 - a) Current Limit
 - b) Fuse For Bias and Fans
- 23) Cooling Blower
- 24) Weight 11 lbs *
- 25) Mounting Panel (Vert/Horiz)
- 26) Power Transformer Separate. May be supplied
by customer, if desired.
- 27) Options Shunt Regulator
Tapered Current Limit

NOTES:

- 1. Maximum peak current is for 1 second.
- 2. Freq response is typical of the amplifier with no compensation. System compensation in most applications usually reduces the response.
- 3. Consult factory concerning application requiring continuous regeneration.
- 4. 120 VAC is for blower and bias power.
- 5. Output voltage max is from 113 VAC RMS bus power.
- 6. Amplifier provides a range of output voltages depending on input bus voltages.
- 7. If motor has 3.75 mHy no external inductor is necessary.
- 8. Output current monitor can drive 5K or more load.
- 9. If any RED LED is on, this indicates a trip of fault logic or a remote off indication. Remove bias power, look for fault and/or wait 10 seconds to reapply bias power. Amplifier will start if fault has cleared.

MODEL	NO. OF AXES	CHASSIS SIZE ** (Inches)		
		L	W	H
A6621	1	17 1/2	6	7 1/4
A6622	2	17 1/2	11	7 1/4
A6623 or 4	3 or 4	17 1/2	15.5	7 1/4

* 1 Axis Chassis without transformer & inductor



** Includes Power Supply & (Regulator)

Customer _____

Amplifier Model _____

Machine _____

AMPLIFIER SETTINGS

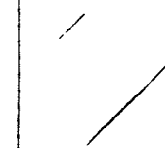
AXIS	EXAMPLE	X	Y	Z
MODULE P/N If Known	A662 Type 120V 60/30 Amp			
POTENTIOMETER SETTINGS FROM FULLY CCW POSITION				
AUX POT	Not Used			
SIGNAL POT	5 Turns			
DIFFERENTIAL INPUT YES/NO	No			
ACH POT	10 Turns			
Tc POT	15 Turns			
CURRENT LIMIT POT	12 Turns			

SPECIAL NOTES:

Date _____