

Pick and Place—Indexer Configuration

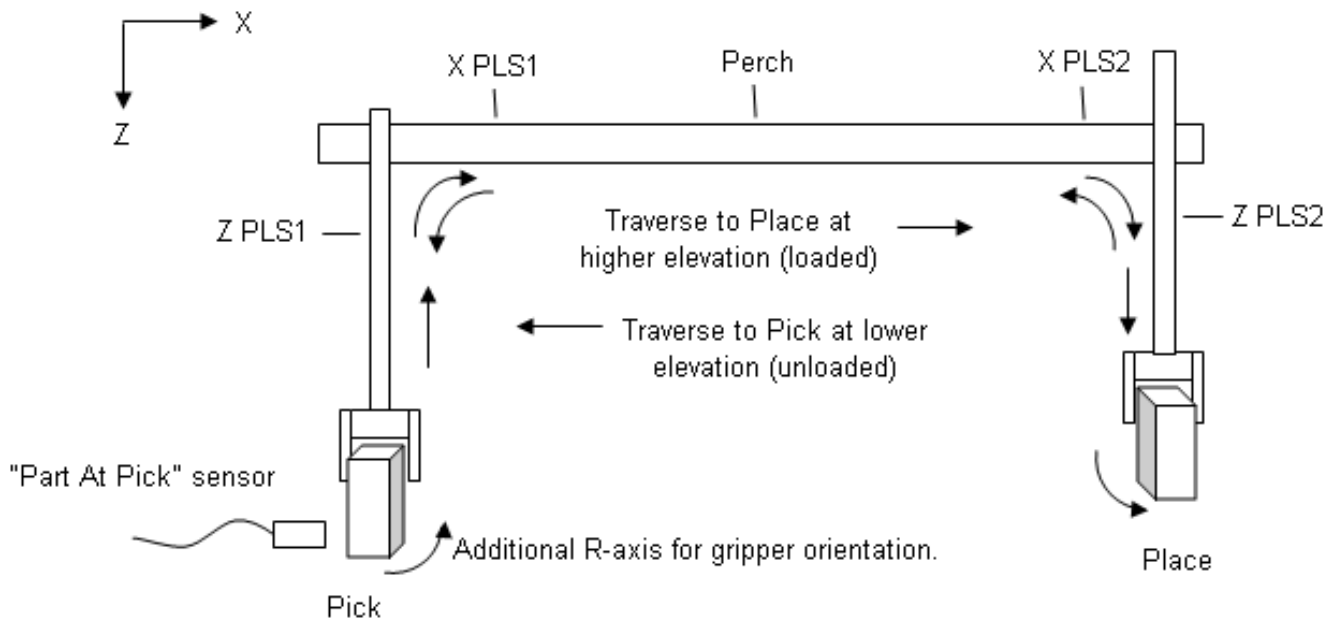

Description of Application

This pre-engineered Indexer configuration is designed for a Pick and Place application.

Pick and Place mechanisms are used to transfer parts between two or more locations. There are many different implementations of Pick and Place mechanisms including Cartesian, SCARA, Delta robots and others. The ORMEC configuration consists of horizontal (X) and vertical (Z) linear actuators with an attached gripper. When a part is detected at a Pick position, the gripper will move to that position and grip the part. It then traverses to the Place position where part is released. Pick and Place systems are often required to operate at fast cycle rates. For this reason, the motion of the X and Z axes are 'overlapped' at the corners of XZ envelope. An additional rotation axis (R) is used to control the gripper orientation.

ORMEC Indexer Implementation

An ORMEC Pick and Place implementation consists of two or three XD-Indexers and an MMI 8000 Series touch screen panel. The MMI is used to calculate motion parameters for the Indexers based upon a set of entered parameters. The MMI also provides logic controller functionality with application logic routines (macros) written in a readable text-style language. This logic is stored in the MMI memory.

The system provides typical control functions for each axis that include: homing, jogging, diagnostics, I/O control, Manual/Auto mode, etc. All machine and process parameters are accessed via the MMI.

On power up, the operator homes the system in Manual mode. The Z-axis homes first followed by the X-axis. A Manual Gripper control is available in both Manual and Auto modes. It is used for purging a part from gripper.

When the cycle starts in Auto mode, the gripper moves to a Perch position where it waits for the part to present at the Pick location. When the part is ready, the gripper moves horizontally toward the Pick position and then the Z-axis descends to the Pick height. At a preprogrammed distance from the Pick height, the gripper slows down for the part approach. When the Pick position is reached, the gripper output (Out8) turns on to grip the part. After a short delay (Gripper On Delay) the gripper moves upward and then horizontally toward the Place position.

As the gripper descends towards the Place position, it slows down at the preprogrammed distance from the Place height. When at the Place position, the gripper output (Out8) turns off to release the part. After a short delay (Gripper Off Delay) the gripper moves upward and then horizontally to the Perch position. If while moving a new part is detected at Pick position, the gripper continues to the Pick position. Otherwise, it stops and

Indexer wiring

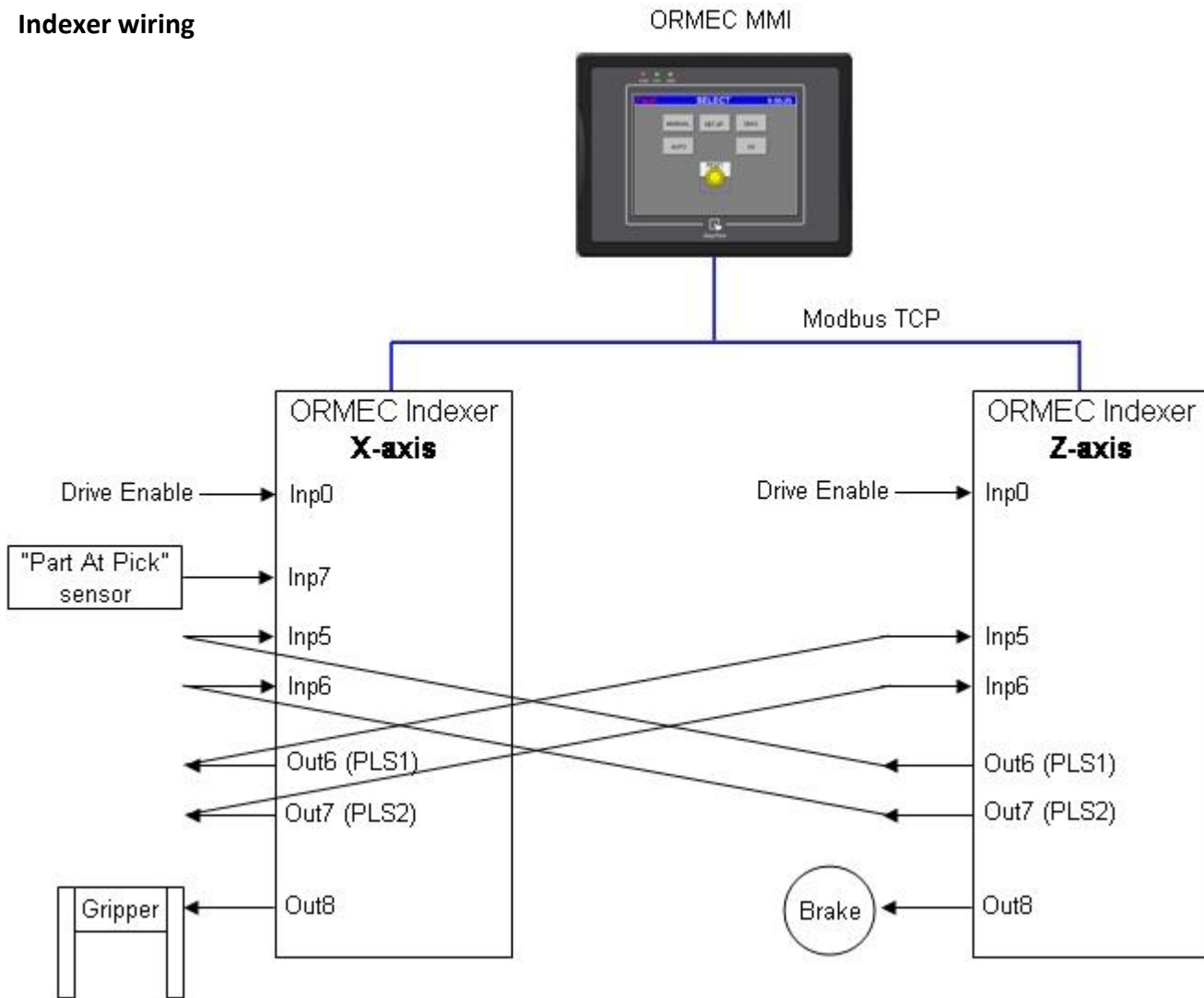

waits at the Perch position for the next part to present at the Pick location.

For faster cycle rates, the X and Z axes motions are 'overlapped' at the ends of the axes stroke. While the X-axis moves toward the Place or Pick positions, the Z-axis starts descending before the X-axis motion is finished. Similarly, when the Z-axis moves upward, the X-axis starts its motion early. Both Indexers have two outputs (Out6 and 7) configured as Programmable Limit Switches (PLS1 and PLS2). The PLS controlled outputs pulse at preprogrammed positions. These outputs are connected

to the inputs (Inp5 and 6) of the other Indexer. These inputs are configured to execute specific motions - 'Pick' and 'Place' on the X-axis and 'Height Loaded' and 'Height Empty' on the Z-axis. The amount of X and Z axes motion 'overlap' is controlled by adjusting the PLS On positions for each actuator via the MMI.

If gripper orientation control is required, a third Indexer is added to the configuration for the R-axis. While the X-axis traverses between the Pick and Place locations, the gripper orientation is adjusted based upon the Pick Angle and Place Angle parameters.

Download Configurations

The configuration files for the XD-Indexer and the MMI 8000 Series project files for this application may be downloaded from the XD-Series Software area of the ORMEC website. For addition information, consult ORMEC sales support at (585) 385-3520 or email sales@ormec.com